

# **TROUBLESHOOTING GUIDE**

**EXEDY**  
EXEDY Clutch Europe Ltd.



# From DAIKIN to EXEDY

Our company pursues excellence in every aspect of our operations. To better express this attitude, in August 1995 we changed our name from Daikin Manufacturing Co., Ltd. to EXEDY Corporation. The new name was coined by combining “Excellence” and “Dynamic” — terms that describe our qualities as a corporation. At the same time we adopted a new corporate logo, composed of three curved lines that form an ‘X’, representing society, customers and employees. The colors used in the corporate logo - known as “excellent blue” and “dynamic red” - now serve as our corporate colors.

## How to Use this Guide

Clutches transmit power for gear shifting and stopping.

The essential qualities of a clutch are:

- Sure disengagement
- Smooth engagement
- Efficient gear change
- Performance and durability
- Absorption of noise and vibration from the engine and power train.

Clutch efficiency depends on the make of car, the clutch usage, as well as maintenance of the clutch. You must choose and fit the appropriate clutch to the vehicle and know how to install, use and operate the clutch correctly. Many clutch complaints and problems are caused by factors other than the clutch component itself — incorrect usage, faulty fitting and poor maintenance can all contribute to the fault. This manual shows a wide range of clutch problems which can occur and lists the reasons for the problem. EXEDY has been supplying and servicing clutches in the market place for many years with advanced technological know-how and much experience gained from supplying the Original Equipment market. We are sure you will appreciate both our service and our guide to fitting, operating and maintaining your clutch.

## Contents

EXEDY Corporate Profile .....	4
EXEDY Worldwide Network .....	5
Pull-Type Clutch Design Technology .....	6
Getting it right the first time .....	7
Grease Application .....	8
Clutch Aligning Tools .....	9
Hydraulic Clutch Pedal Adjustments .....	10
Concentric Slave Cylinder (CSC) Installation .....	11
Self-Adjusting-Clutch Tool Box .....	12
Flywheel: DMF vs SMF .....	13
<b>Troubleshooting</b>	
Slipping .....	14
Shudder .....	24
Non-Release .....	27
Noisy .....	40
Pedal/other .....	49
Performance Clutches .....	52
Driveline Misalignment .....	56
Torque Specifications for Flywheel & Pressure Plate .....	57
Beware of Imitations & Inferior Products .....	58
Metric & Imperial Measurement Conversion Table .....	60
Product Selection Guide .....	61
Warranty .....	BC



## Leaders in drivetrain technology

As a leading manufacturer of drivetrain components, EXEDY Corporation is committed to providing superior products, technology and services. We bring decades of experience and a wealth of know-how to our efforts to develop products that meet the needs of today's industries.

Already at the top of our field, EXEDY is now moving forward towards new challenges in the 21st century.

- 1950** Incorporated as DAIKIN Manufacturing Co., Ltd.
- 1973** Established DYNAX Corporation in Hokkaido.
- 1975** Ueno Division Started in Mie.
- 1977** Established DAIKIN Clutch U.S.A., Inc.(present EGP)
- 1981** Kawagoe plant started in Saitama.
- 1995** Changed Corporate name from "Daikin Mfg. Co., Ltd." to "EXEDY Corporation"
- 1997** Listed on 1st Section of Tokyo Stock Exchange.
- 1999** **QS-9000 & ISO9001** Certified in March
- 2000** ISO14001 Certified in June
- 2001** Strategic Alliance with Aisin Seiki Co., Ltd.
- 2004** **ISO/TS16949** Certified in June



New head building

Consolidated Sales (Unit : ¥100 million)

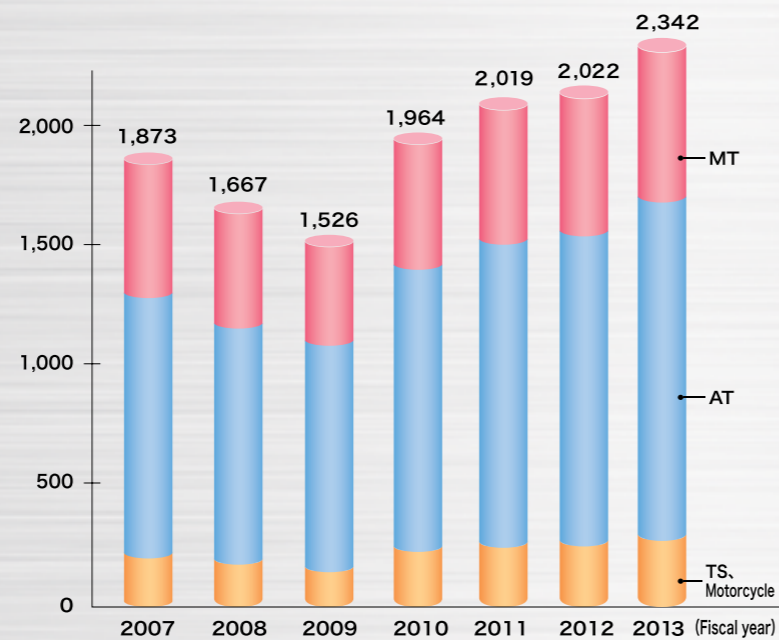

**Established** July 1950

**President & CEO** Haruo Shimizu

**No. of Employees As of 3/31/2013** Consolidated **17,108**

**Sales (FY2013)** Consolidated **US\$ 2.28 Bil.** [Yen 234.2 bil.]

Global Network

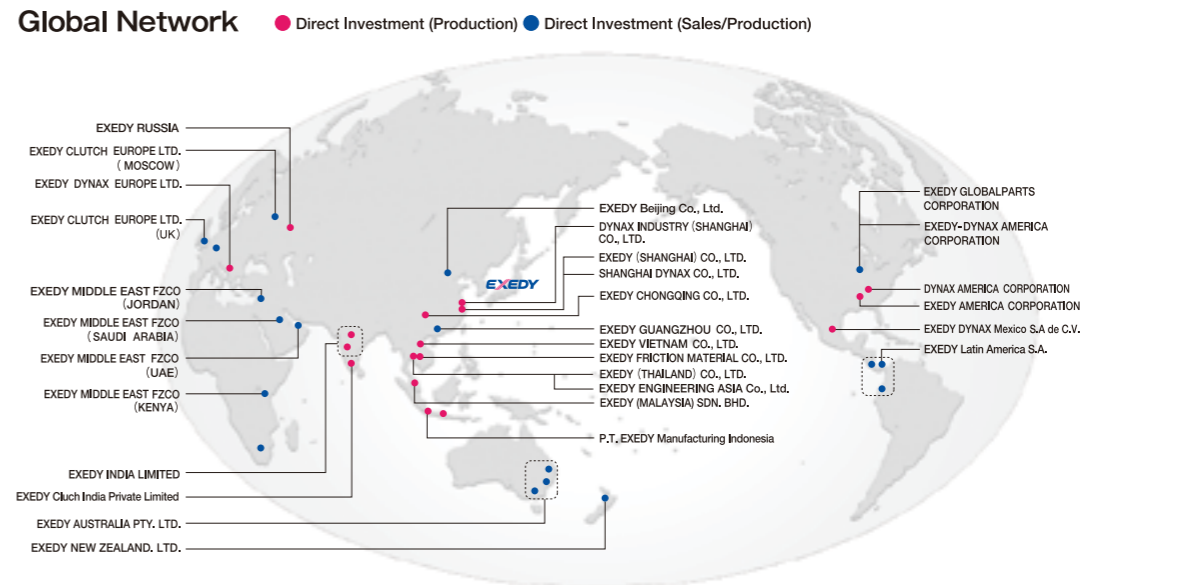

Aftermarket Group

① EXEDY Globalparts Corporation (Michigan, U.S.A.)

8601 Haggerty Road South, Belleville, MI 48111, U.S.A.  
TEL: 1-734-397-3333  
FAX: 1-734-397-7300



⑦ EXEDY Chongqing Co., Ltd. (Chongqing, China)

No.4 Longjing Road, North New Economic Development Zone, Chongqing, 401142, CHINA  
TEL: 86-23-62924439  
FAX: 86-23-62900348



② EXEDY Clutch Europe Ltd. (Cheshire, U.K.)

Unit 2, Rokeby Court, Manor Park, Runcorn, Cheshire, WA7 1RW, U. K.  
TEL: 44-1928-571850  
FAX: 44-1928-571852



⑧ EXEDY (Thailand) Co., Ltd. (Chonburi, Thailand)

700/316 Moo 6, Bangna-Trad Road, Tumbon Don Hua Roh, Amphur Muang, Chonburi 20000, THAILAND  
TEL: 66-38-214-423  
FAX: 66-38-214-422



③ EXEDY Australia Pty. Ltd. (Melbourne, Australia)

21 Fiveways Boulevard, Keysborough, Victoria 3173, AUSTRALIA  
TEL: 61-3-9701-5556  
FAX: 61-3-9701-5684



⑨ P.T. EXEDY Indonesia (Karawang, Indonesia)

Jl. Permata V Lot EE 3 Kawasan Industri KIIC Karawang 41361 Jawa Barat, Indonesia  
TEL: 62-21-89114666  
FAX: 62-21-89114568



④ EXEDY New Zealand Ltd. (Auckland, New Zealand)

151 Wairau Road Glenfield Auckland, NEW ZEALAND  
TEL: 64-9-444-0901  
FAX: 64-9-444-0903



⑩ EXEDY India Ltd. (Greater Noida, India)

Plot No.L-4, M.I.D.C. Industrial Area, Chikalthana, Aurangabad 431 210, Maharashtra, no M.H.INDIA  
TEL: 91-240-2484014  
FAX: 91-240-2484403



⑤ EXEDY Middle East Fzco (Dubai, U.A.E.)

P.O.BOX 18199, Warehouse No. ZE5 & ZE6 Jebel Ali Free Zone, Jebel Ali Dubai, U.A.E  
TEL: 971-4-883-2244  
FAX: 971-4-883-2500



⑪ EXEDY India Ltd. (Aurangabad, India)

Plot No.9, Udyog Kendra Industrial Area, Greater Noida, 201 304, U.P., INDIA  
TEL: 91-750-3131000  
FAX: 91-120-2397086



⑥ EXEDY Guangzhou Co., Ltd. (Guangzhou, China)

No.406 E-Area, Longfu Car Accessories Centre, Hengfu Road, Guangzhou, CHINA  
TEL: 86-20-83489166  
FAX: 86-20-83489370



EXEDY (Malasia) Sdn. Bhd. (Negeri Sembilan, Malasia)

PT 16748, Jalan Permata 1/5, Arab-Malaysian Industrial Park 71800 Nilai, Negeri Sembilan, MALASIA  
TEL: 60-6-7992988  
FAX: 60-6-7996388



EXEDY Latin America, S.A. (Marbella, Panama City)

P.H. World Trade Center, Piso 3, Oficina 303 Marbella, Panama City, Republic of Panama  
P.O. Box number 0832-00599  
TEL: 507-395-7122/7123  
FAX: 507-395-7124

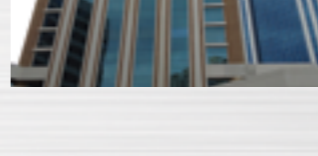

**STUDY BEFORE ASSEMBLY**

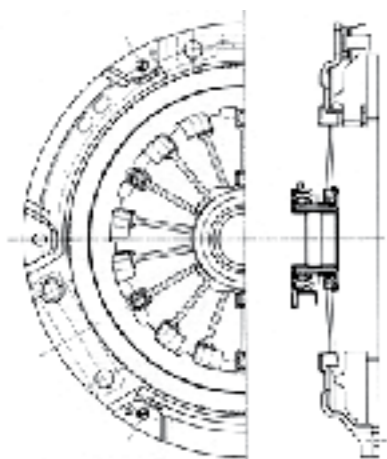

**PATENTS PENDING**

One for Pull Clutch  
Four for Release Bearing Mechanism

**STUDY BEFORE INSTALLATION**

**INSTALLATION AND SNAP-IN PROCESS**

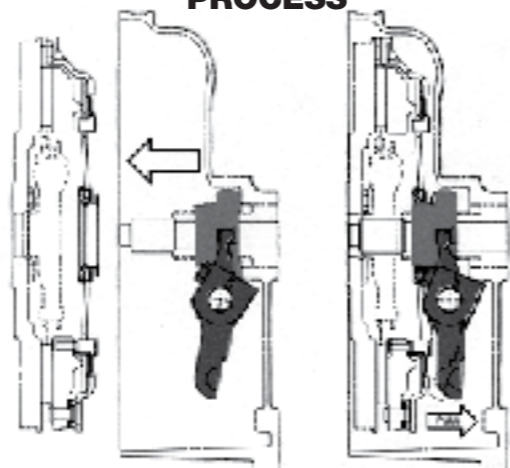

Install bearing on to clutch fork, install transmission (G/Box) then the release fork must be pulled in the direction reverse to the release firmly. The bearing is then snapped in.

**DISASSEMBLY**

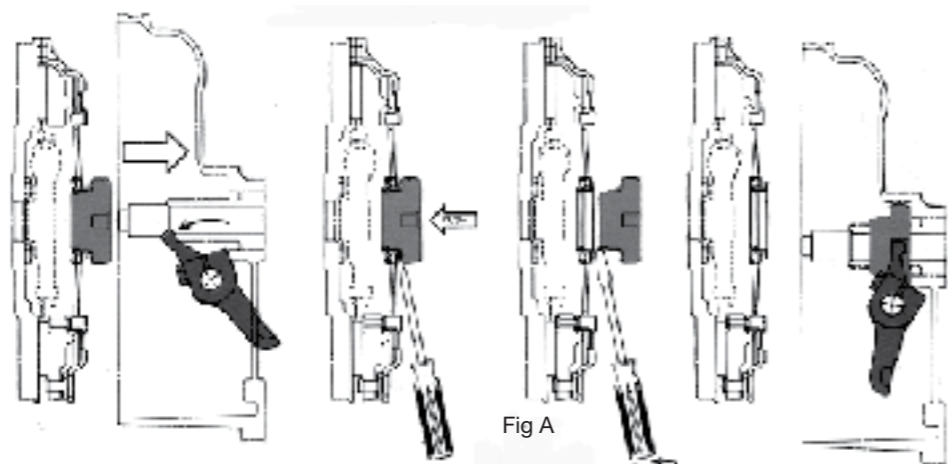

**SNAP - OUT PROCESS**

Move the bellhousing back approximately 30 to 40mm, insert a screwdriver and twist as in figure A. The bearing will then snap out from the clip mechanism.

**Good Fitting Practice ...**

**Get it right the first time, installing your new EXEDY Clutch**

- Getting it right the first time. It is vital to diagnose the cause of clutch malfunction before clutch replacement, i.e. check hydraulic system - bearing free travel - clutch cable, oil leaks and check for any signs of red dust when the old clutch is being removed. Any or all of these concerns must be corrected before installing a new clutch.
- Ensure that the clutch supplied is correct for the application. If you're unsure, consult your EXEDY Clutch Catalogue or your supplier, as fitting a clutch to the wrong application will void the warranty.
- The Flywheel must be machined as shown below (Fig 2) or warranty will be void. Check the spigot bearing or the spigot bush and replace if necessary. Please note pilot/spigot bush noises are more apparent when the engine and transmission systems are cold (i.e. in the morning).

around and the hub section of the disc does not foul on the casting of the clutch cover assembly or the flywheel. A suitable clutch aligning tool will ensure correct alignment, assist in ease of installation and avoid spline damage. (burrs on the splines can contribute to the clutch not functioning correctly). Ensure that the flywheel dowels are aligned to the cover. Tighten the bolts in a diagonal pattern and never use air tools to install a clutch cover assembly. Torquing down the bolts in an uneven pattern can cause the lever struts to dislodge, or in the case of a diaphragm cover cause the diaphragm fingers to be uneven.

- When the cover assembly has been torqued securely to the flywheel, ensure that the diaphragm tips (in the case of a lever type cover assembly, the release lever tips) are in a parallel position in relation to the flywheel (see Fig 3) and do not go over centre of the parallel position.

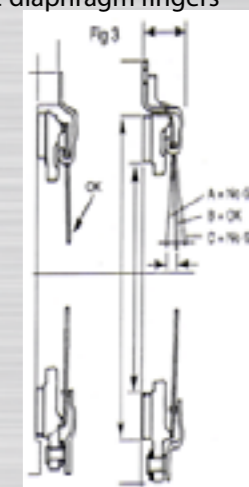

- Before fitting, check the clutch for any shipping damage. Next clean the gearbox main drive shaft splines, and then check that the clutch disc slides freely on the shaft. Lightly grease the shaft splines with high melting point grease. Always ensure the bell housing is degreased and is free of any dust and that fibres from the worn clutch are removed. If the clutch is a large size pull type check the ID of the bearing head for correct spline size before installation. Lack of lubrication/dry splines will cause failure to disengage gears and also cause clutch drag.
- Check the clutch release fork for cracks, check the clutch cable for stretch signs and check the release bearing guide tube for any wear. Always lightly grease the outside diameter of the tube, this will allow smooth sliding of the bearing carrier. Always check the bearing on clutch release fork. Move the fork forwards and backwards i.e. in both directions, to ensure the bearing is secure and does not foul any part (clutch fork or bell housing) before refitting gearbox.
- Place the clutch cover assembly over the clutch disc, after checking that the disc is the right way

- Re-fit the gearbox, taking care not to bend the clutch disc. Never hang the gearbox on the clutch disc or use any force to align the gearbox shaft.
- Check all bell housing dowels are in the correct position and tighten the bell housing bolts. Ensure there is no dirt or foreign material between the mating surfaces of the engine and the bell housing.
- Perform any clutch adjustments to the vehicle manufacturer's specifications.
- Always check the clutch cable if you are unable to obtain disengagement when a new clutch is fitted. Start your checking process by replacing the cable. If it is a hydraulic system check the clutch master cylinder and the slave cylinder, ensuring there is no air in the system. This is essential to obtain maximum travel for disengagement.
- Road test the vehicle and never abuse a newly fitted clutch. Allow 1,000 km run in and always adjust free travel on your new clutch at 1,000km and 3,000 km. Thereafter, adjust at every 10,000km.

**WARNING:** Do not use EXEDY clutches in any situation where engine RPM's may exceed manufacturer's specifications — a pressure plate could explode unexpectedly causing serious injury or death to vehicle occupants and bystanders. The clutch cover and bell housing will not protect against exploding pressure plates. Please refer to the EXEDY application listings for the correct fitment.

# Grease Application

## Step 1



A tube of high melting point grease is supplied with every EXEDY clutch kit. Open the tube and apply a small amount of grease to the splined hub.

**\*Important, do NOT use the entire contents of the tube.**

Also lubricate the throw out fork to bearing contact area and pivot surface with the remainder of the grease.

## Step 2



Slide the clutch disc onto the input shaft.

## Step 3



Remove any excess grease from the splined hub.

## Step 4



Do not contaminate the friction material as this will introduce the possibility of shudder and/or slip.

EXEDY has the following clutch alignment tools for passenger and commercial vehicles

Vehicle	Spline	Spigot Diameter	Tool
✓ Ford	25.4 X 24	15.9	DCT-01
✓ Ford	26.9 X 10	17	DCT-FC10
Ford	25.4 X 23	17	DCT-FF23
✓ Holden	28.6 X 10	15	DCT-GM10
✓ Holden	25.4 X 24	17	DCT-24
Holden	28.6 X 26	17	DCT-48
✓ Holden	25.4 X 24	15.9	DCT-01
✓ Holden	28.5 X 26	15	DCT-GM26
Honda	26.0 X 24	20	DCT-61
Honda	26.2 X 24	15	DCT-88
✓ Hyundai	22.2 X 20	15	DCT-20
Hyundai	19.1 X 18	15	DCT-77
✓ Isuzu	25.4 X 24	15.9	DCT-01
✓ Mazda	23.8 X 22	15	DCT-05
Mazda	19.1 X 18	15	DCT-77
✓ Mazda	22.2 X 20	15	DCT-20
Mazda	25.4 X 23	15	DCT-FB8
✓ Mitsubishi	22.2 X 20	15	DCT-20
Mitsubishi	30.2 X 14	17	DCT-81
✓ Mitsubishi	25.4 X 23	15	DCT-03
Mitsubishi	19.1 X 18	15	DCT-77

Vehicle	Spline	Spigot Diameter	Tool
Mitsubishi	22.2 X 20	17	DCT-49
Mitsubishi	25.4 X 23	17	DCT-FF23
✓ Nissan	20.6 X 18	N/R	DCT-21
✓ Nissan	25.4 X 24	15.9	DCT-01
Nissan	23.8 X 21	11.9	DCT-12
✓ Subaru	25.4 X 24	11.9	DCT-90
Suzuki	22.2 X 20	9.9	DCT-47
✓ Toyota	28.6 X 21	11.9	DCT-11
Toyota	23.8 X 21	11.9	DCT-12
Toyota	27.0 X 20	24.4	DCT-17
✓ Toyota	28.6 X 21	15	DCT-74
Toyota	28.6 X 10	15	DCT-16
Toyota	31.7 X 14	11.9	DCT-70
Toyota	32.0 X 14	15	DCT-112
Truck	38.1 X 10	25.4	DCT-HT150
Truck	38.1 X 10	19	DCT-HT150A
Truck	44.45 X 10	25.4	DCT-HT175
Truck	44.45 X 10	19	DCT-HT175A
Truck	50.8 X 10	30	DCT-HT200
Truck	50.8 X 14	30	DCT-HT214

✓ Included in DCTKIT-01 alignment tool kit

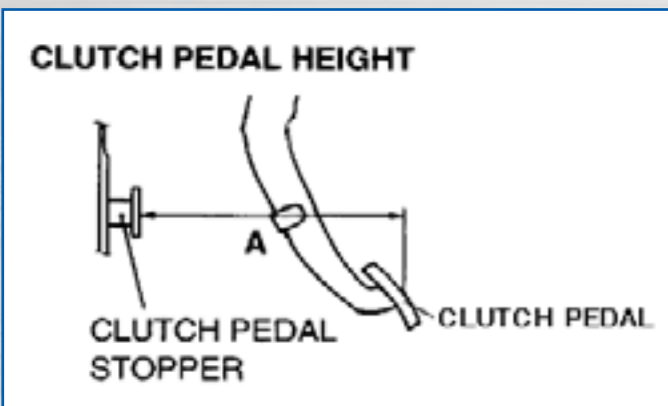

Measure the clutch pedal height. Standard value (A): 202.1 - 206.1 mm (7.96 - 8.11 inch)

CAUTION: Do not push in the master cylinder push rod at this time, otherwise the clutch will not operate properly.

Measure the clutch pedal clevis pin play. Standard value (B): 1 - 3 mm (0.04 - 0.12 inch)

CAUTION: Do not push in the master cylinder push rod at this time, otherwise the clutch will not operate properly.

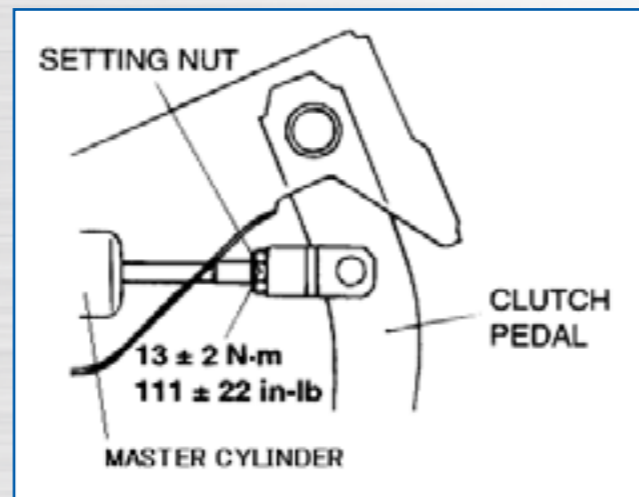

After completing the adjustments, confirm that the clutch pedal free play (measured at the face of the pedal pad) and the distance between the clutch pedal (the face of the pedal pad) and the clutch pedal stopper when the clutch is disengaged are within the standard value ranges. Standard value (C): 4 - 13 mm (0.16 - 0.51 inch) Standard value (D): 114.3 mm (4.5 inches) or more.

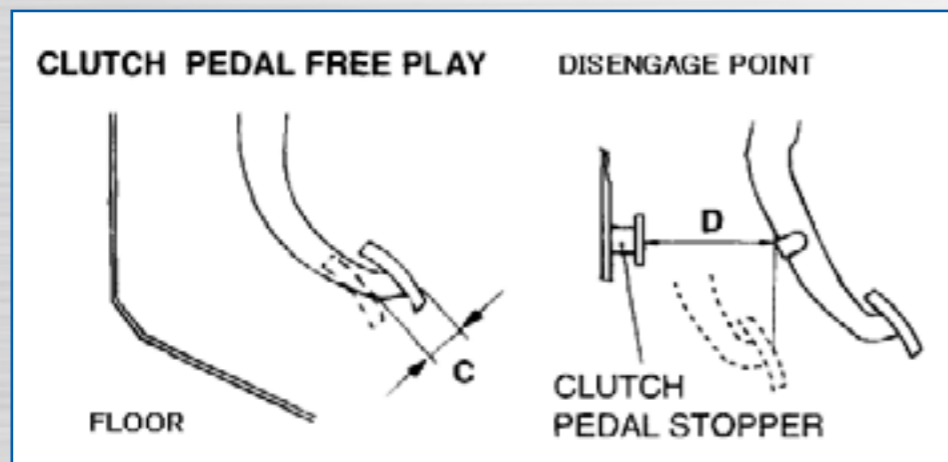

## Concentric Slave Cylinder (CSC)

To prevent the possible premature failure of the CSC (Concentric Slave Cylinder), it is essential the technician follows some basic instructions while handling the CSC:

- Do not operate the cylinder by hand prior to installation. The cylinder does not contain any brake fluid (lubricant) at this stage and damage to the seal may occur. Similarly, the construction of the cylinder is comprised of two (2) major components. The cast body and an inner flanged tube that is pressed into the body. Should the cylinder be stroked prior to installation, the inner flanged tube can be forced out of position rendering the cylinder unserviceable.
- Ensure that old fluid and debris has been thoroughly flushed through the system prior to fitment of the new cylinder.
- The cylinder should be located over a clean first motion shaft and bolted evenly, as per the manufacturer's specification, to a clean face of the transmission.
- Failure to comply with this instruction may result in damage to the cylinder and seals resulting in faulty operation.
- Make sure any "O" rings are replaced and located with care.

It is recommended that the cylinder be bled as per the manufacturer's instructions and avoid using pressure bleeding.

**DO NOT COMPRESS**



**UNCOMPRESSED**



Scan the QR code to watch the CSC video.

## Self-Adjusting-Clutch Tool Box



Self Adjusting Clutches can be found in many modern motor vehicles. Due to the intricate design and construction it is important that when fitting a Self Adjusting Clutch that the appropriate tools are used.

The SAC tool enables the professional removal and replacement of SAC-Clutches (Self-Adjusting-Clutch) in a smooth operation minimising the potential for damage to the cover assembly and/or self adjusting mechanism during the installation process.

The SAC Tool also ensures that the centre of the clutch disc is correctly aligned with the crankshaft; correct centring of the clutch disc also allows the input shaft to be positioned in the clutch disc hub smoothly minimising the risk of clutch disc or hub profile damage.

The Tool kit consists of:

1. Clamping tools (3 & 4 point clamping tool pieces).
2. Clutch compression strut.
3. Clutch alignment tools (15/23mm, 15/28mm & 15/34mm sizes).
4. Clutch resetting tool.
5. Clamping tool handles (x2).
6. Additional clutch alignment tools (x3). Blue (19.75mm), Pink (20.75mm) & Black (stepped 19/15/14mm).
7. Knurled nuts (x4) for use with threaded bolts.
8. 5 sets of 4 threaded bolts (M6x1.00, M8x1.25, M7x1.00, M8x1.25 & M6x1.00).



Scan the QR code to watch the SAC tool kit installation process

## Dual Mass and Single Mass Flywheels

### What is Dual Mass Flywheel?

The Dual Mass Flywheel derives its name from the two main components (or masses) that operate independently of each other. The primary component (or mass) is fitted with a ring gear and sensor ring (if applicable) and is attached to the crank shaft. This primary component usually incorporates a dampening mechanism typically made up of torsion springs and friction washers that are ideally suited to absorbing torsional vibrations within the drivetrain. The clutch unit is then bolted onto the secondary component. Quite simply a DMF is a damper for your drivetrain.

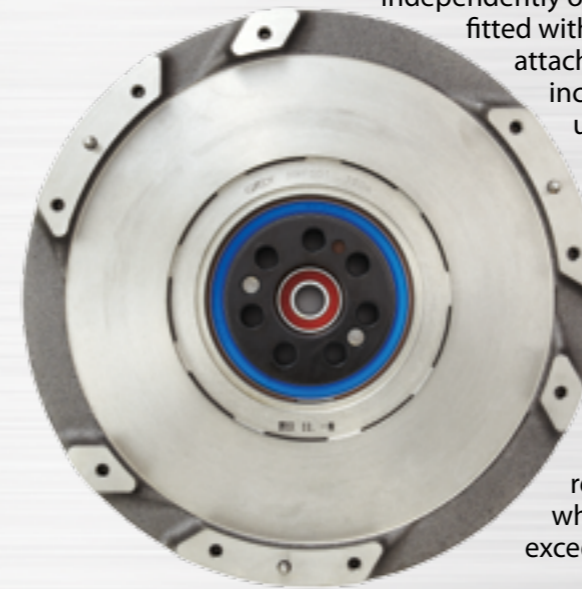

### Why does a DMF fail?

A DMF can fail for a number of reasons, but the most common cause will be wear and tear. Like any other component on a vehicle, the DMF will wear out over time. Other causes of failure may relate to driving technique, overloading the drivetrain when towing or increasing torque to a point where it exceeds the torque capacity of the flywheel.

### How do I know if the DMF needs to be replaced?

Flywheel specifications vary from manufacturer to manufacturer and as such, there is no one test that indicates whether the flywheel has reached the end of its service life. There are however some generic tell-tale signs that indicate to the installer that the flywheel should be replaced such as grease or oils leaks; or noisy operation. EXEDY recommends that the best and safest option is to replace the DMF each time the clutch is replaced. Furthermore, we strongly recommend that you do not grind, machine or attempt to repair a DMF. These actions are fraught with danger as it is not possible to machine or grind the flywheel surface accurately without removing the secondary component from the primary mass. Attempting to machine and rebuild a worn DMF will usually result in the premature failure of not only the flywheel but the new clutch set as well.

### What are the options when it comes to replacing the DMF?

The replacement of a worn DMF system with another DMF and clutch package is an obvious option, however, the cost of this option is sometimes prohibitive and as such EXEDY has developed a range of Single Mass Flywheels (SMF) which are sold together with the clutch cover assembly, clutch disc and release bearing to replace the DMF clutch system. The main advantage of the SMF clutch package is the price – these systems are generally cheaper to purchase. Furthermore, as the SMF has no moving components, they can be machined and re-installed into the vehicle when a subsequent new clutch is fitted thereby reducing the future cost of maintaining the clutch system. The conventional SMF is extremely robust and is, for example, the preferred choice for vehicles used in racing or commercial applications. While the SMF replacement clutch system is a popular choice, it is however important to note that despite the durability and price advantages, these system do not possess the same dampening characteristics as a DMF and on occasion, may not sound or feel like the DMF system that is being replaced.

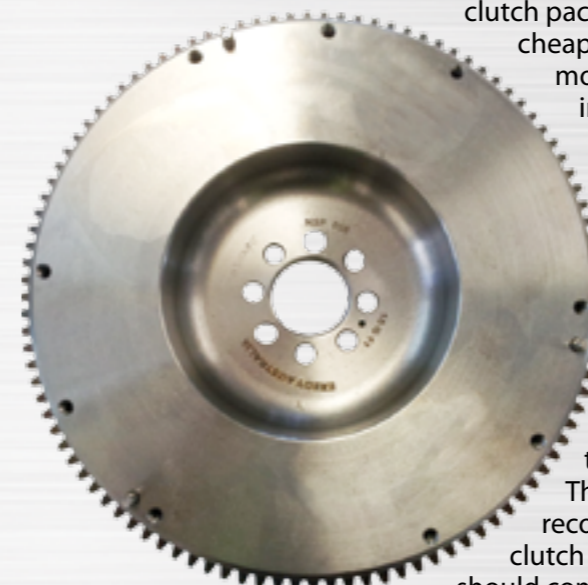

Therefore, when recommending a replacement clutch and flywheel system you should communicate to your customer the pros and cons of replacing the DMF or of fitting an SMF in its place. This will enable your customer to make an informed decision regarding which replacement system best suits their budget and needs.

Scan the QR code to watch the DMF-SMF video.



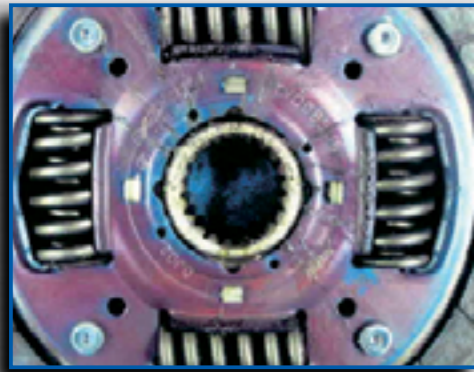

**PROBLEM:** Oily facings  
**SYMPTOM:** Slipping clutch/Shuddering clutch  
**CAUSE:** Excessive grease or low viscosity grease causes this problem  
 Melted grease on the friction material will affect the friction coefficient causing facing failure  
**SOLUTION:** Lightly grease the spline, wipe off excessive grease and ensure there is smooth sliding of clutch disc on main drive shaft  
 Use the correct grade of grease as specified by the vehicle manufacturer



**PROBLEM:** Broken facings  
**SYMPTOM:** Slipping clutch/Shudder/Judder/Noisy clutch  
 Unable to drive  
**CAUSE:** Following factors lead to high temperature of friction surface, resulting in this problem  
 1. Driving with a foot on the clutch pedal  
 2. Overloading vehicle  
 3. Improper starting gear  
 4. Clutch pedal height or free play maladjustment  
 5. Oil/grease contamination  
**SOLUTION:** 1.~ 3. Driver education.  
 4. Adjust pedal free play according to the service manual



\*Do not over grease input shaft or disc during installation



**PROBLEM:** Oily Facings  
**SYMPTOM:** Slipping clutch/Shuddering/Juddering clutch  
**CAUSE:** 1. Faulty main drive oil seal  
 2. Faulty rear main bearing oil seal  
**SOLUTION:** 1. Replace clutch disc  
 2. Replace faulty oil seals

**PROBLEM:** Broken facing material on the clutch disc  
**SYMPTOM:** No drive/Noisy clutch  
**CAUSE:** Parts of the disc friction material are broken from the rivet along with part of the cushioned segment. This is due to down shifting of gear i.e. the speed of the vehicle at the rear wheels was travelling faster than the engine RPM, when gear was changed down  
**SOLUTION:** Driver education

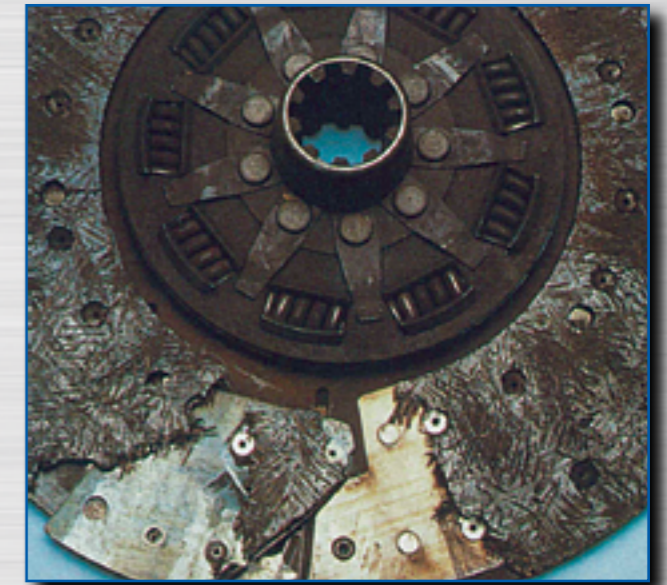

**PROBLEM::** Broken clutch facings flywheel side  
**SYMPTOM:** Clutch slips/Does not disengage  
**CAUSE:** 1. Overloading vehicle  
 2. Clutch disc has been replaced but not clutch pressure plate cover assembly  
 3. Lack of applied load (insufficient diaphragm spring pressure or coil spring pressure)  
**SOLUTION:** 1. Do not overload vehicle  
 2. Replace with complete clutch kit

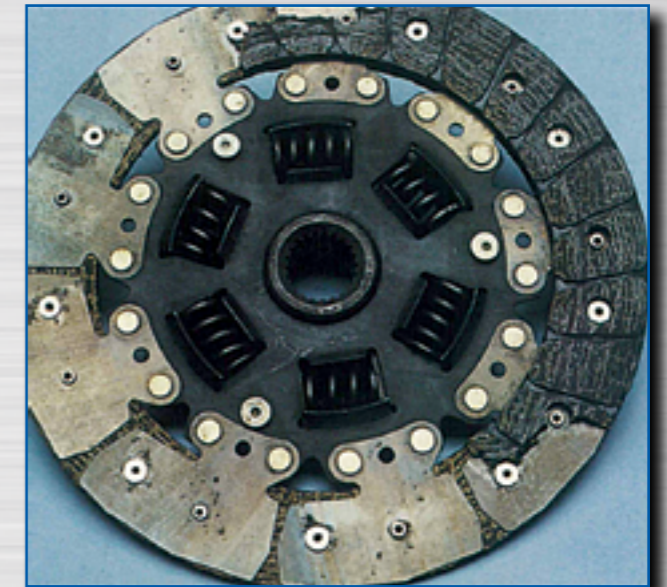

**PROBLEM:** Broken segments on clutch disc, sprung hub separated from facings  
**SYMPTOM:** Sudden clutch failure/No drive/Noisy clutch  
**CAUSE:** Cushion spring steel segments uniformly separated from hub area due to:  
 1. Faulty or worn pilot bearing or bushing  
 2. Hanging gearbox during installation  
 3. Dirt or chips between the mating surfaces of the engine bolt up areas.  
 4. Gearbox/transmission lock up. (i.e. Gear tooth jam)  
**SOLUTION:** 1. Check pilot bushing or bearing and replace if necessary. Align gearbox and use the assistance of a transmission jack and always clean mating surfaces before installation  
 2. Check gearbox for metal fragments then remove and repair as necessary

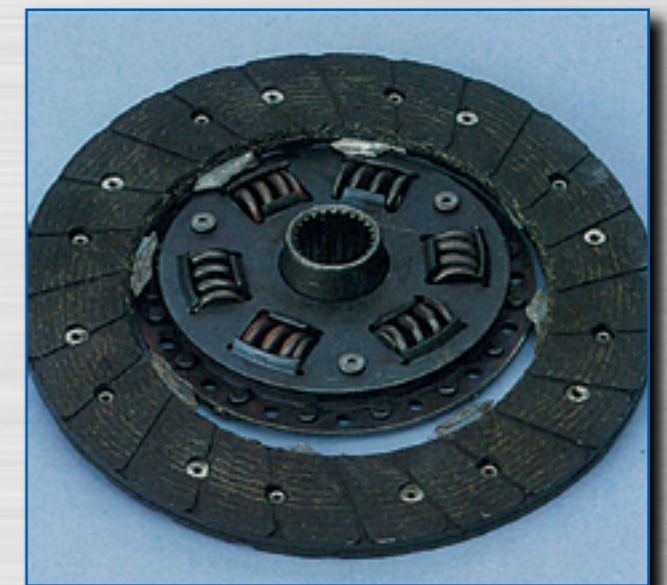



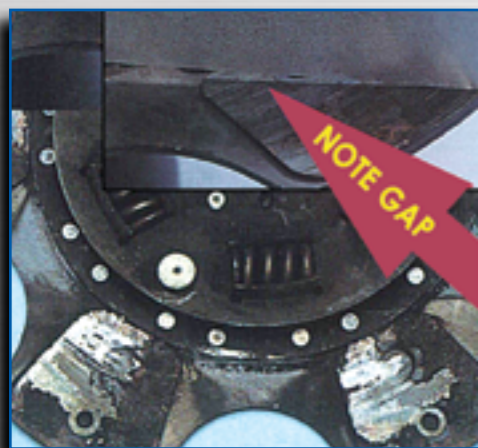

**PROBLEM:** Premature wear (Cerametallic button type clutch disc)

**SYMPTOM:** Slipping clutch.

**CAUSE:** Bedding-in procedure not observed for Cerametallic buttons

**SOLUTION:** Driver education; observe bedding in procedure. Due to the weight of this disc type, it takes longer for its rotation to slow when the clutch cover is in the released position. The clutch pedal must be depressed for longer especially in vehicles without a clutch brake attached to the system

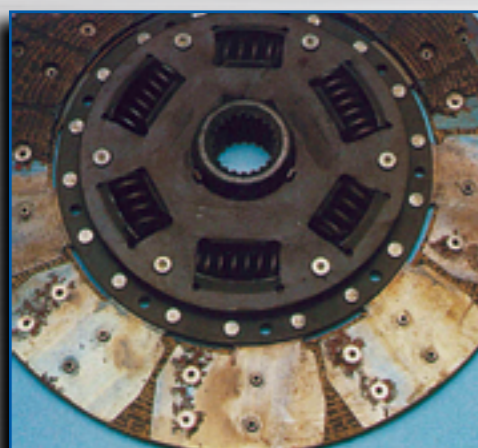

**PROBLEM:** Broken facing of clutch disc on clutch cover assembly, pressure plate side

**SYMPTOM:** Noisy clutch/slipping clutch

**CAUSE:**

1. Improper driving practice; down changing gear constantly
2. The speed of the vehicle is actually higher than of the shifted to gear
3. The gearbox and drivetrain revolutions are turning faster than the speed of the engine at the time: sudden clamp damaged the facings
4. Excessive grease on the transmission input shaft

**SOLUTION:** Driver education, proper fitting practice

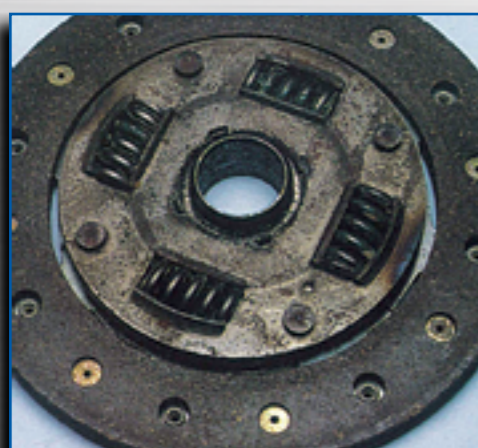

**PROBLEM:** No drive/Noisy clutch

**SYMPTOM:** Splines completely disintegrated on clutch disc

**CAUSE:**

1. Clutch disc not tested on spline before installation
2. Missing spigot/pilot bearing or bushing.

**SOLUTION:**

1. Always check the number of splines on the clutch disc, match those on the transmission input shaft and that the disc slides smoothly onto the input shaft prior to installation
2. Check and replace spigot/pilot bearing of bushing. (Mini UK and Europe: Check primary gear for worn bushing; if worn replace)

**PROBLEM:** Burst clutch disc/No transmitted power

**SYMPTOM:** Clutch slip

**CAUSE:**

1. The clutch was engaged while coasting downhill causing the facings to burst through extreme shock

2. Gear being shifted down when the vehicle engine is revving lower than the transmission ratios, resulting in excessive RPM at the driveline end. This is beyond the capacity of the burst strength specifications of the friction material

3. Lack of free travel caused by faulty clutch slave cylinder or air over hydraulic system (common in Japanese truck applications). With a new clutch kit installed keeping in mind the diaphragm tips/ release lever tips are further down due to the thickness of the new clutch disc. The slave cylinder piston will now be operating further towards the end of the cylinder where it has not worked for some time, depending on adjustment and travel. This area in the cylinder may possibly be corroded. Keeping in mind that brake fluid is a hygroscopic liquid, which is very absorbent of moisture. Moisture corrodes and could result in the piston jamming and not returning, therefore, causing the release mechanism to activate the clutch in a semi disengaged position. The above corrosion problem would also apply to the air canister in the air over hydraulic assist system. A partly disengaged clutch generates extreme heat affecting the clamp load of the diaphragm spring/coil spring ultimately causing the friction material to burst. This is always indicated by the blue and burnt coloring on the pressure plate cover assembly casting and clutch disc. A strong burnt smell is also noticeable

4. Driver resting foot on the clutch pedal

5. Lack of free travel and proper adjustment.

6. Wrong differential speed selected to match with chosen gear (trucks with 2 speed differentials.)

**SOLUTION:**

1. Driver education for 1, 2, 4, and 6
2. Check clutch release mechanism, air system and hydraulics for 3
3. Adjust clutch to manufacturer's specifications for 5

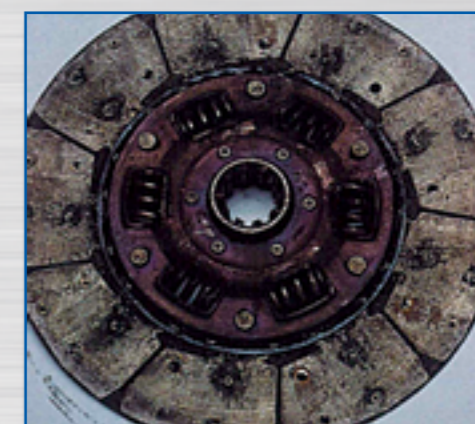

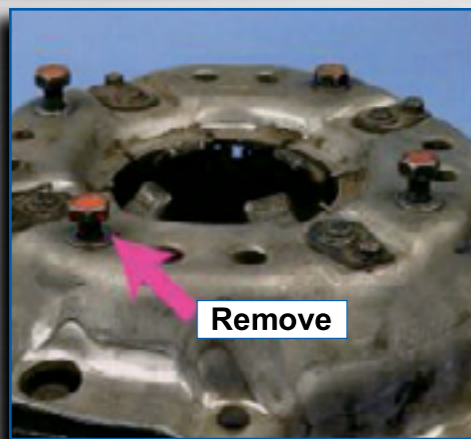

Remove hold down bolts

**PROBLEM:** Hold down bolts still in cover assembly  
**SYMPTOM:** Clutch slipping/Noisy clutch  
**CAUSE:** Clutch cover pressure plate assembly hold down bolts (to assist during installation) not removed  
**SOLUTION:** Remove hold down bolts painted in red. (Do not remove clutch lever adjustment nuts which are not painted in red)

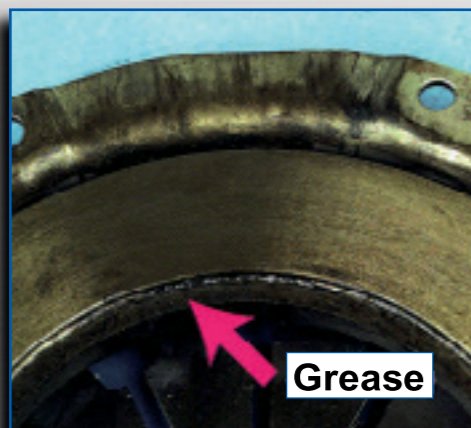

Grease on friction surface

**PROBLEM:** Oil or grease contamination on friction surface  
**SYMPTOM:** Slipping clutch/Judder  
**CAUSE:** Excessive grease or low viscosity grease causes this problem  
 Melted grease on the friction material affects the friction coefficient and caused slipping or judder  
**SOLUTION:** 1. Remove excess grease from spline prior to installing clutch  
 2. Replace leaking engine or transmission oil seals



Friction surface, cover discoloration

**PROBLEM:** Discoloration on friction surface and/or clutch cover  
**SYMPTOM:** Slipping clutch  
**CAUSE:** 1. Driver abuse / improper driving technique  
 2. Incorrectly adjusted or faulty release mechanism extreme heat transfer due to prolonged clutch slipping has weakened the main spring of the clutch cover  
 3. Engine torque exceeds that of the clutch  
**SOLUTION:** 1. Driver education  
 2. Replace faulty parts and adjust to the manufacturer's specifications  
 3. Upgrade to an appropriate EXEDY sports clutch

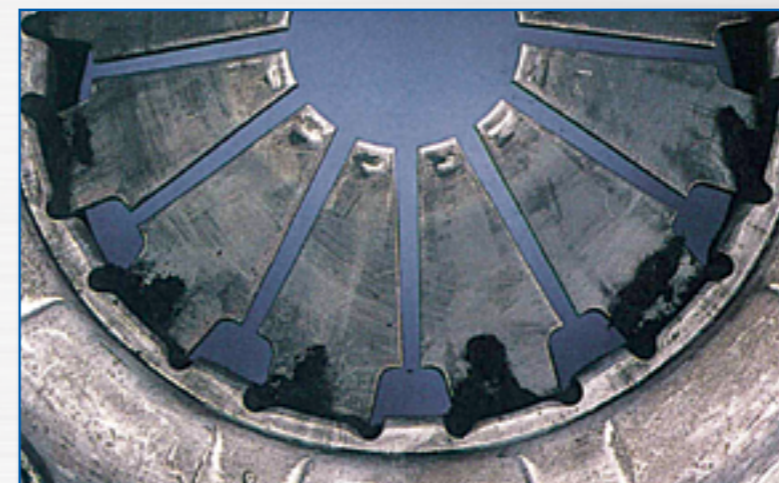

**PROBLEM:** Worn clutch disc facing fibres and dirt lodged between diaphragm spring and clutch cover housing, causing loss of clamp load

**SYMPTOM:** Slipping clutch/Clutch drag

**CAUSE:** 1. Bell housing not degreased and cleaned. Careless installation of new clutch  
 The new clutch disc has not worn but the fibres that have become lodged in the new clutch cover are that of the previously worn clutch. It is a requirement due to ventilation designs that the bell housing area be free from old fibres, dirt and grease when installing a new clutch

2. This problem is common in 4 wheel drive vehicles when an inspection cover or a clutch fork cover boot has not been replaced when installing a new clutch

**SOLUTION:** 1. Ensure the bell housing is thoroughly degreased and clean of dirt and fibres before installing a new clutch

2. Ensure inspection locations and boots are replaced, tightened and well located

*Note: These problems are common on farm vehicles, vehicles travelling on sand and 4x4 recreational vehicles.*

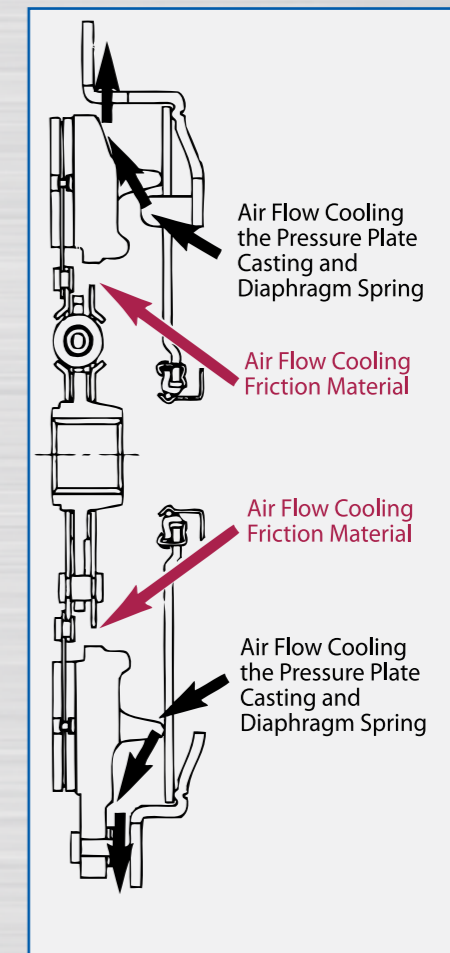

**PROBLEM:** 1. Installation assist clips not removed  
 2. Slipping clutch/excessive free travel  
 3. Unable to adjust  
 4. Will not transmit power

**SYMPTOM:** Clutch slipping just after installing new clutch

**CAUSE:** Clutch cover pressure plate assembly hold down clips (to assist ease of installation) have not been removed

**SOLUTION:** Remove clips after installation

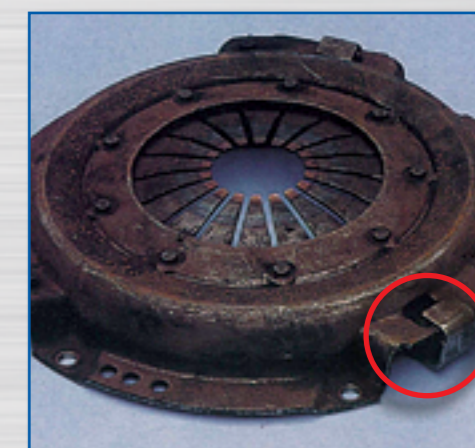

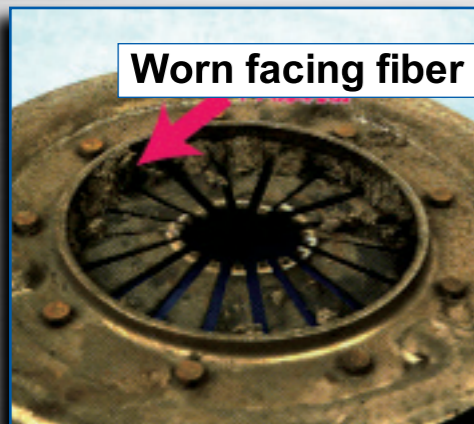

Worn facing fibers and dirt lodged

- PROBLEM:** Worn clutch disc facing fibers and dirt lodged between diaphragm spring and clutch cover housing
- SYMPTOM:** Difficult to disengage gear/ Slipping clutch
- CAUSE:**
1. Bell housing not degreased and cleaned
  2. Careless installation of new clutch
- SOLUTION:** Ensure the bell housing is thoroughly degreased and clean of dirt and fibers before installing a new clutch

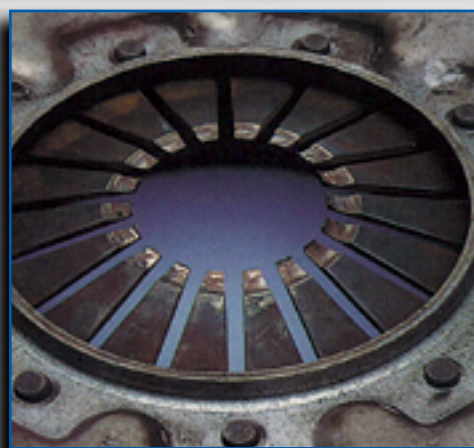

- PROBLEM:** Excessive wear on diaphragm tips and a highly glazed pressure plate casting
- SYMPTOM:** Slipping clutch/Shudder/Judder
- CAUSE:**
1. Lack of free travel/bearing riding on diaphragm
  2. Driver resting foot on the clutch pedal
  3. Nose cone worn/bearing stuck on a worn spot and not returning to original position
  4. Clutch slave cylinder corroded or worn and piston not returning to allow free travel
  5. Stretched or sticky cable
- SOLUTION:**
1. Adjust free play in clutch to the manufacturer's specification
  2. Driver education
  3. Replace gearbox main drive nose cone
  4. Replace clutch slave cylinder and check pressure build up in clutch master cylinder
  5. Replace cable. (Do not re-oil old cable)



- PROBLEM:** No clamp load onto clutch disc
- SYMPTOM:** Slipping clutch
- CAUSE:**
1. Incorrect flywheel profile (no step or too much of a recess)
  2. Inferior remanufacture of old clutch cover
- SOLUTION:**
1. Always re-grind flywheel to the manufacturers specification
  2. Replace only with a new EXEDY pressure plate cover assembly

- PROBLEM:**
1. Hold down bolts still in pressure plate assembly
  2. Unable to adjust
  3. Will not transmit power
- SYMPTOM:** Clutch slipping just after installing new clutch
- CAUSE:** Clutch cover pressure plate assembly hold down bolts (to assist during installation) not removed
- SOLUTION:** Remove hold down bolts
1. Do not remove clutch lever adjustment nuts
  2. Common in Japanese trucks



- PROBLEM:** Excessively worn or damaged dual mass flywheel
- SYMPTOM:** Slipping clutch after fitting new clutch, without replacing old dual mass flywheel
- CAUSE:** Arc springs within the dual mass flywheel (not visible from the exterior) are worn or broken
- SOLUTION:** Always replace dual mass flywheel when fitting a new clutch (as recommended by the vehicles manufacturer)



- PROBLEM:** Damaged clutch thrust bearing. Diaphragm spring excessively worn
- SYMPTOM:** Continuous clutch thrust bearing noise
- CAUSE:** The clutch has not been adjusted correctly since installation or the clutch has never been adjusted during any routine service. The clutch thrust bearing and the diaphragm of the clutch cover pressure plate assembly have worn indentations into each other
- SOLUTION:**
1. Fit new clutch kit as it is too late for adjustment of old clutch
  2. Always check free travel at service





Malfunction of cylinder assembly

**PROBLEM:** Jammed, Leaking or completely destroyed Concentric Slave Cylinder (CSC)

**SYMPTOM:** Slipping clutch/Difficult to disengage gears

**CAUSE:** **Slipping clutch:**  
Over stroking or excessive preload of the cylinder due to incorrect release mechanism adjustment or blockage in the hydraulic line limiting return fluid flow back to the master cylinder

**Difficult to disengage gears:**

- Air in system due to incorrect hydraulic bleeding procedure
- Fluid contamination resulted in premature failure of the cylinders internal piston seal
- Blockage in the hydraulic line has resulted in complete cylinder failure
- Mounting surface on front of transmission not cleaned prior to fitment of cylinder, preventing o-ring seal properly

**SOLUTION:**

- Always flush the hydraulic system and only use new hydraulic fluid when fitting a new cylinder. Adjust release mechanism to the manufacturer's specifications. Replace faulty hydraulic components (master cylinder, dampening valves, hydraulic lines etc)
  - Adjust release mechanism to the manufacturer's specifications
  - Always flush the hydraulic system and only use new hydraulic fluid when fitting a new cylinder
  - Replace faulty hydraulic components (master cylinder, dampening valves, hydraulic lines etc).
  - Always ensure the mounting surface is clean and the o-ring seal (where required) is used to provide a positive seal

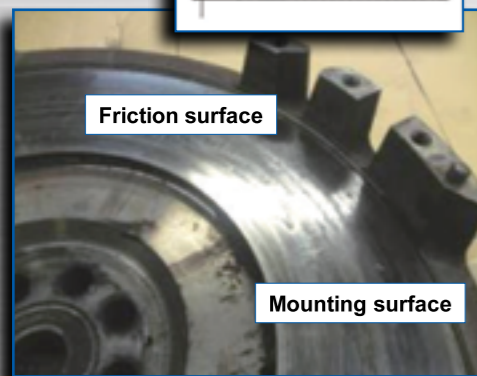
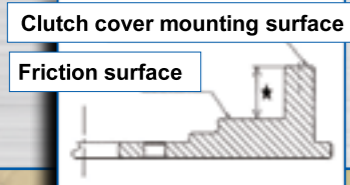

Flywheel with deteriorated friction surface

**PROBLEM:** Incorrect flywheel profile

**SYMPTOM:** Slipping/Difficulty engaging or disengaging gears

**CAUSE:** **Slipping:**  
Flywheel not ground when clutch was replaced or not ground to correct manufacturer's specification, resulting in lack of applied clamping force from the clutch pressure plate

**Difficult to disengage gears:**  
Excessive flywheel step or recess ground too shallow into the flywheel has resulted in the clutch cover levers or diaphragm being lower than manufacturer's specifications

**SOLUTION:** Grind the flywheel to the manufacturer's specification each time the clutch is replaced

**PROBLEM:** Abnormal wear on the release bearing guide tube

**SYMPTOM:** Sticky or notchy pedal/Slipping clutch

**CAUSE:** Driveline misalignment. No grease applied to guide tube

**SOLUTION:** Refer misalignment tips on page 56. Apply appropriate grease. Renew worn parts

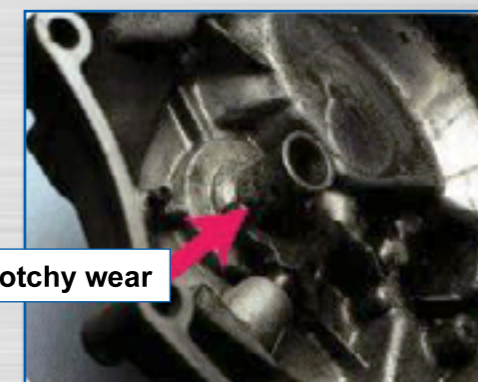

Notchy wear on front cover

**PROBLEM:** Melted grease on clutch disc side plate

**SYMPTOM:** Clutch shudders/Judders and/or slips

**CAUSE:**

- Excessive grease on transmission input shaft.
- Melted grease on friction material will affect friction coefficient of disc facing

**SOLUTION:**

- Lightly grease spline, wiping off excessive grease and ensure there is smooth sliding of the clutch disc on the main shaft
- Replace clutch disc with new disc unit
- Use only high melting point grease

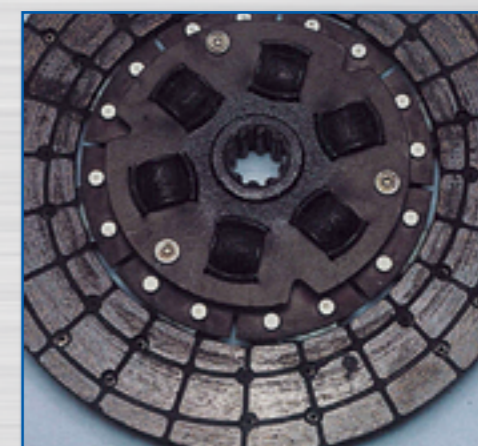

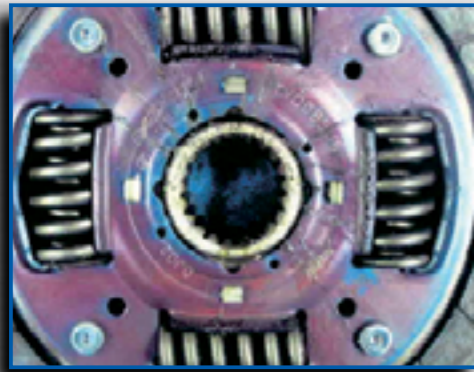

**PROBLEM:** Oily facings  
**SYMPTOM:** Slipping clutch/Shuddering clutch  
**CAUSE:** Excessive grease or low viscosity grease causes this problem  
 Melted grease on the friction material will affect the friction coefficient causing facing failure  
**SOLUTION:** Lightly grease the spline, wipe off excessive grease and ensure there is smooth sliding of the clutch disc on the main drive shaft  
 Use grade of grease specified by vehicle manufacturer



**PROBLEM:** Broken facings  
**SYMPTOM:** Slipping clutch/Shudder/Judder/Noisy clutch. Unable to drive

**CAUSE:** Following factors lead to high temperature of friction surface, resulting in this problem  
 1. Driving with a foot on the clutch pedal  
 2. Overloading vehicle  
 3. Improper starting gear  
 4. Clutch pedal height or free play maladjustment  
 5. Oil/grease contamination

**SOLUTION:** 1.~ 3. Driver education  
 4. Adjust pedal free play according to the service manual

\*Do not over grease input shaft or disc during installation



**PROBLEM:** Oily Facings  
**SYMPTOM:** Slipping clutch/shuddering/juddering clutch  
**CAUSE:** 1. Faulty main drive oil seal  
 2. Faulty rear main bearing oil seal  
**SOLUTION:** 1. Replace clutch disc  
 2. Replace faulty oil seals

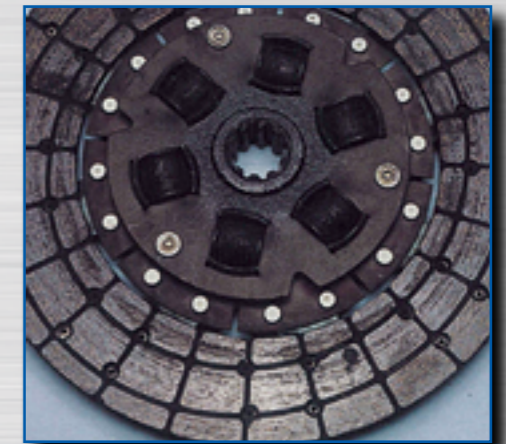

**PROBLEM:** Melted grease on clutch disc side plate  
**SYMPTOM:** Clutch shudders/Judders and/or slips  
**CAUSE:** 1. Excessive grease on transmission input shaft.  
 2. Melted grease on the friction material will affect friction coefficient of disc facing  
**SOLUTION:** 1. Lightly grease spline, wiping of excessive grease and ensure there is smooth sliding of clutch disc on main drive  
 2. Replace clutch disc with new disc unit  
 3. Use only high melting point grease

**PROBLEM:** Mirror finish on pressure plate friction surface

**SYMPTOM:** Judder

**CAUSE:** 1. Prolonged slipping of clutch  
 2. Clutch slave cylinder corroded or worn and piston not returning freely

**SOLUTION:** 1. Driver education not to activate the clutch in an excessive semi disengagement position  
 2. Replace slave cylinder

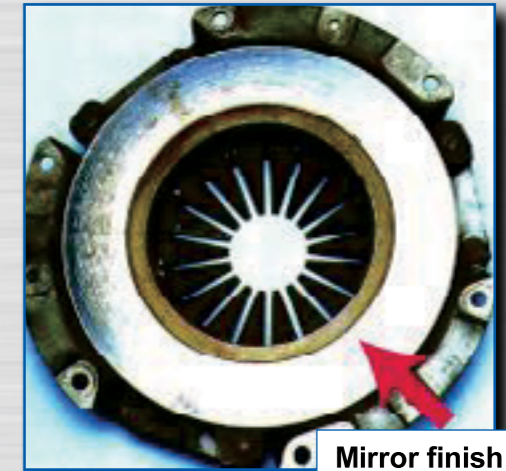

Mirror finish

Mirror finish on pressure plate

**PROBLEM:** Oil or grease contamination on friction surface

**SYMPTOM:** Slipping clutch/Judder

**CAUSE:** Excessive grease or low viscosity grease causes this problem  
 Melted grease on the friction material affects the friction coefficient and causes slipping or judder

**SOLUTION:** 1. Remove excess grease from spline prior to installing clutch  
 2. Replace leaking engine or transmission oil seals

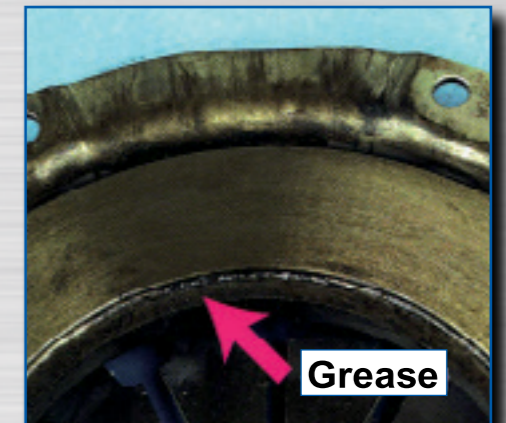

Grease

Grease on friction surface

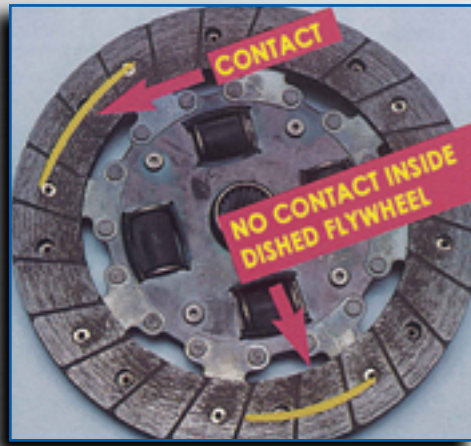

- PROBLEM:** 1. Vehicle vibrates/shakes when clutch is being released (at take off)
- SYMPTOM:** Clutch shudder/Judder/Chattering
- CAUSE:**
1. Flywheel not even/warped
  2. Deep scoring indentations from previous worn clutch
- SOLUTION:** Always resurface flywheel before installing new clutch. Refer to figure below

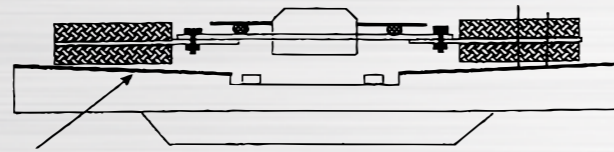

Belled out surface might look smooth but uneven

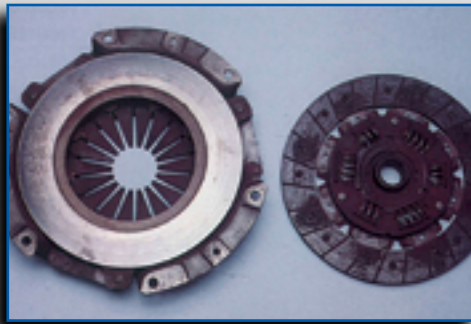

- PROBLEM:** Excessive scoring on clutch cover pressure plate running surface
- SYMPTOM:** Shuddering/Juddering clutch
- CAUSE:**
1. Installation error/misalignment (refer to misalignment tips on page 56)
  2. Inferior clutch facings
  3. Diaphragm spring load not to specification
- SOLUTION:**
1. Replace complete clutch and pilot (spigot) bearings
  2. Avoid misalignment on installation

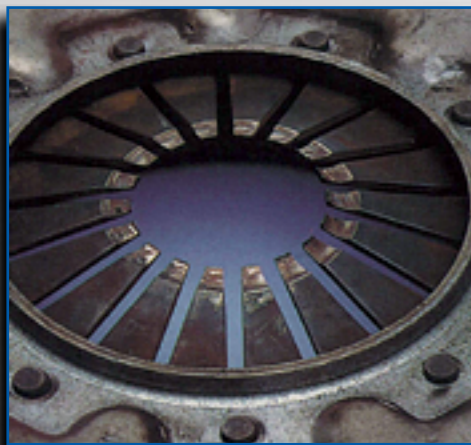

- PROBLEM:** Excessive wear on diaphragm tips and a highly glazed pressure plate casting
- SYMPTOM:** Slipping clutch/Shudder/Judder
- CAUSE:**
1. Lack of free travel/bearing riding on diaphragm
  2. Driver resting foot on the clutch pedal
  3. Nose cone worn/bearing stuck on a worn spot and not returning to original position
  4. Clutch slave cylinder corroded or worn and piston not returning to allow free travel
  5. Stretched or sticky cable
- SOLUTION:**
1. Adjust free play in clutch to the manufacturer's specification
  2. Driver education
  3. Replace nose cone (gearbox main drive nose cone)
  4. Replace clutch slave cylinder and check pressure build up in clutch master cylinder
  5. Replace cable. (Do not re-oil old cable)

- PROBLEM:** Contact mark on the teeth of spline and the end of hub
- SYMPTOM:** Difficult to disengage gears
- CAUSE:** Input shaft splines not in line with splines on disc and excessive force used to re-install transmission
- SOLUTION:** During the installation of transmission, align drive line;
- height
  - angle
  - spline teeth
- then fit without excessive force

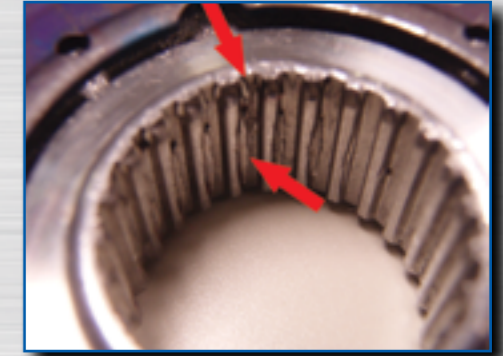

- PROBLEM:** Burrs at the end of hub due to uneven wear on the spline teeth
- SYMPTOM:** Difficult to disengage gears
- CAUSE:** Misalignment between engine crank shaft and transmission main shaft causes this problem during installation of transmission
- SOLUTION:**
1. Replace deteriorated pilot bearing or bush
  2. Reinstall parts after removal of contamination or scratch on the mating surface of bell housing



- PROBLEM:** Damaged torsion springs
- SYMPTOM:** Unable to disengage gears/Noisy clutch
- CAUSE**
1. When engine torque is higher than clutch torque, this misapplication causes springs to deteriorate
  2. Misalignment between engine crank shaft and transmission main drive shaft causes this problem during installation of transmission
- SOLUTION:**
1. Choose and fit the appropriate EXEDY clutch to suit the application
  2. Replace deteriorated pilot bearing, bush, missing or damaged dowels and remove any contamination or burrs from mating surfaces between the engine and transmission



Damaged torsion springs



- PROBLEM:** Damaged facing material
- SYMPTOM:** Difficult to disengage gears
- CAUSE:** Clutch disc has been dropped possibly during installation or damaged in transit
- SOLUTION:** 1. Inspect parts prior to installation  
2. Handle parts carefully

- PROBLEM:** Broken clutch facings flywheel side
- SYMPTOM:** Clutch slips/Does not disengage
- CAUSE:** 1. Overloading vehicle  
2. Clutch disc has been replaced but not clutch pressure plate cover assembly  
3. Lack of applied load (insufficient diaphragm spring pressure or coil spring pressure)
- SOLUTION:** 1. Do not overload vehicle  
2. Replace with complete clutch kit

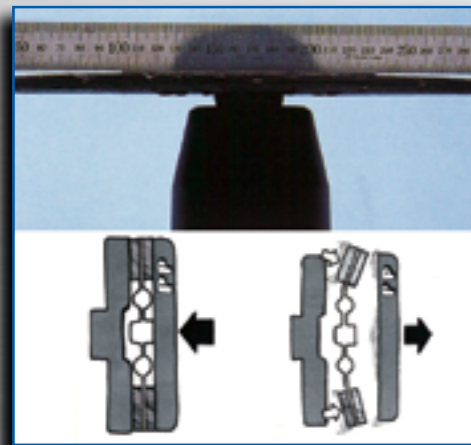
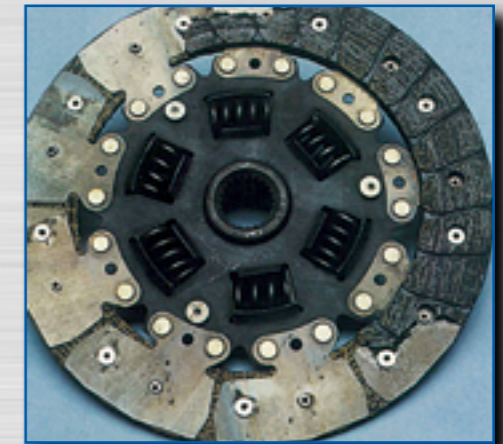

- PROBLEM:** Warped and bent clutch disc
- SYMPTOM:** Difficult gear change/Crashing noise in gearbox/ Non release
- CAUSE:** 1. Hanging of gearbox during installation  
2. Not aligning clutch disc and forcing main drive into the spline, therefore, bending the clutch disc hub towards the engine as seen in photograph  
*Note: Hanging the gearbox during installation pulls the clutch disc hub towards the gearbox*  
3. Driver resting their foot on the clutch pedal causing clutch slip due to the clutch being in a semi disengaged position. This has caused extreme heat which has warped the disc
- SOLUTION:** 1. Do not hang gearbox during clutch installation Always use a clutch aligning tool  
2. Do not force gearbox into clutch disc spline  
3. Driver education/check free travel

- PROBLEM:** Clutch disc completely ruined
- SYMPTOM:** Sudden clutch failure
- CAUSE:** Clutch disc fitted incorrectly i.e. back to front
- SOLUTION:** 1. Always check clutch disc on flywheel for fouling before installation

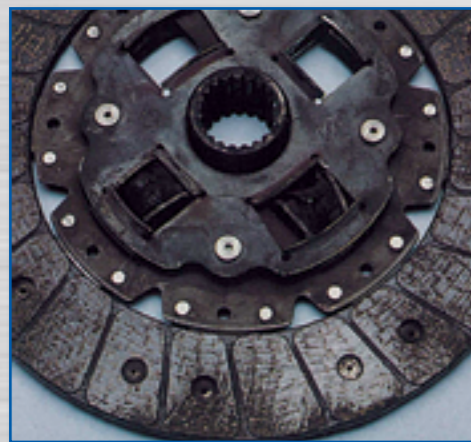

- PROBLEM:** Broken rubber dampeners
- SYMPTOM:** Noisy/No disengagement (rubber torque stopper type clutch disc)
- CAUSE:** 1. Use of inferior or imitation clutch disc  
2. Clutch wound past torque capacity  
3. Inferior rubber compound
- SOLUTION:** 1. Fit genuine EXEDY clutch  
2. Driver education

- PROBLEM:** Damaged torsion springs
- SYMPTOM:** Gearbox rattle/noisy clutch - diesel applications. Other descriptions of problem are: gearbox rollover noise or tick over noise
- CAUSE:** When engine torque is higher than clutch torque this causes springs to deteriorate. This is due to the very different characteristics in design of this particular clutch disc
- SOLUTION:** Choose and fit the appropriate EXEDY clutch to suit the application (e.g. silent type design or LTD design)



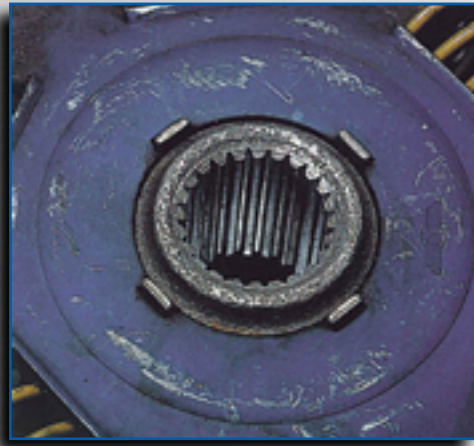

**PROBLEM:** Damaged or burred splines on the clutch disc  
**SYMPTOM:** Unable to re-install transmission after fitting replacement clutch  
**CAUSE:** Careless fitting practice, clutch disc not checked on the transmission input shaft prior to installation, different number of splines on the clutch disc compared to that on the transmission input shaft  
**SOLUTION:** 1. Always refer to EXEDY packaging instructions before installing clutch  
 2. Try clutch disc on main drive for smooth sliding before installation



**PROBLEM:** Damaged or burred splines on clutch disc  
**SYMPTOM:** Difficult to disengage gears  
**CAUSE:** Defective pilot bearing or bush. This causes angular wear on the spline teeth, not allowing the clutch disc to slide on the spline teeth. It also causes the clutch disc to possibly stick on to the flywheel or not separate from the clutch cover pressure plate assembly. This results in poor separation or no disengagement  
**SOLUTION:** Fit new pilot bearing or bush

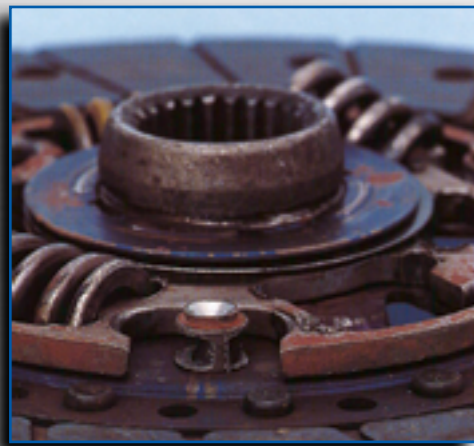

**PROBLEM:** Torsion dampener stopper springs thrown out of side plate/stop pins worn  
**SYMPTOM:** Noisy clutch/unable to engage or disengage gear  
**CAUSE:** 1. Improper driving practice i.e. "dropping" the clutch whilst engine is turning at extremely high revolutions  
 2. Down changing of gears i.e. 5th gear to 2nd gear by low speed/high driving gear method  
 3. Wear on the stop pins indicates the clutch plate has been wound past specified torque loading. This has the same affect on the springs  
 4. Misalignment



**SOLUTION:** 1. Driver education  
 2. Refer misalignment tips on page 56  
 3. Vehicle used for performance driving. It is advisable to use clutch disc with higher stopper torque capacity. Refer to the EXEDY Performance/ Sports Clutch listings

**PROBLEM:** Signs of red dust on clutch disc (as seen in photo)  
**SYMPTOM:** Clutch inoperative  
**CAUSE:** Severe misalignment between the mating surfaces of the bell house and the rear of motor  
**SOLUTION:** 1. Refer misalignment tips on page 56  
 2. Engine and gearbox modifications where mating surfaces are not parallel or the engine and gearbox do not mate at an absolute centre line are to be rectified  
 3. Metal dust cover plates overlapping each other during installation must be avoided



**PROBLEM:** Torque stopper springs broken  
**SYMPTOM:** Noisy clutch with vibration  
**CAUSE:** 1. Misalignment between engine crank-shaft centre and gearbox main drive  
 2. If the torsion springs are damaged along with the torque stopper pin then it is evident that the clutch has been wound past its torque capacity  
**SOLUTION:** 1. Refer misalignment tips on page 56  
 2. Driver education



**PROBLEM:** Diaphragm has fouled on clutch disc  
**SYMPTOM:** Difficult to engage/disengage gear  
**CAUSE:** 1. Flywheel depth or step incorrect  
 2. Clutch thrust bearing fallen off gearbox nose cone slide  
 3. Clutch disc too thick  
 4. Incorrectly adjusted (overthrow of clutch mechanism)  
**SOLUTION:** 1. Check flywheel depth or step height  
 2. Check for wear on release bearing gearbox nose cone slide  
 3. Check clutch disc thickness  
 4. Refer to clutch adjustment procedure or replace cable

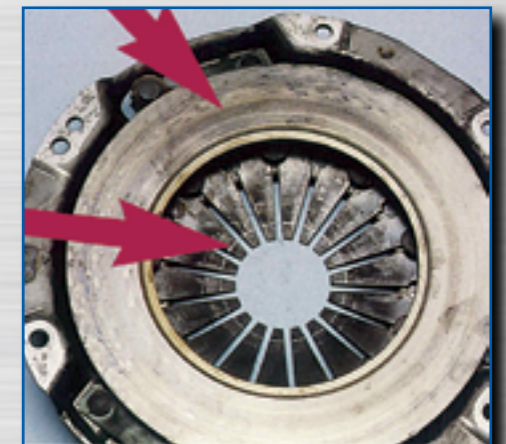



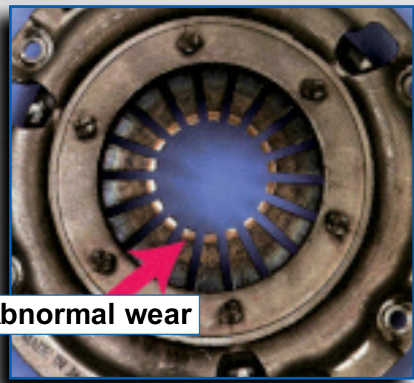

Abnormal wear

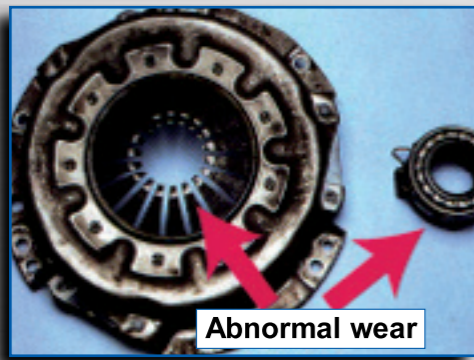

Abnormal wear

Excessive wear on diaphragm tips

**PROBLEM:** Excessive wear on diaphragm tips  
**SYMPTOM:** Difficult to disengage gear/ Noisy clutch  
**CAUSE:** Driveline misalignment. Wear to both the diaphragm levers and inside fulcrum of the clutch cover result in less pressure plate lift and difficulty in engaging gears

**SOLUTION:** Refer misalignment tips on page 56

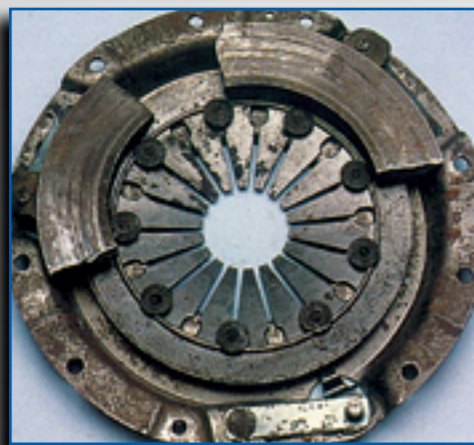

**PROBLEM:** Burst pressure plate casting  
**SYMPTOM:** No disengagement.  
**CAUSE:** 1. Over revving of engine that has exceeded vehicle manufacturer's specifications  
 2. Over heating of casting due to constant abuse of clutch. The main spring has weakened through extreme influence of heat

**SOLUTION:** 1. Driver education  
 2. Do not use EXEDY covers where engine has been modified to exceed manufacturer's RPM specifications  
 3. Use EXEDY specified sports clutch. Refer to EXEDY standard range or EXEDY Sports listings where covers are manufactured with nodular iron castings



PP heat distortion

Pressure plate heat distortion

**PROBLEM:** Warped clutch cover assembly by reuse  
**SYMPTOM:** Clutch drag  
**CAUSE:** Insufficient contact due to warped pressure plate. Only clutch disc was replaced which caused partial contact on the friction surface and slipped during heavy load condition

**SOLUTION:** Always replace the clutch disc, clutch cover and clutch thrust/release bearing when replacing clutch system

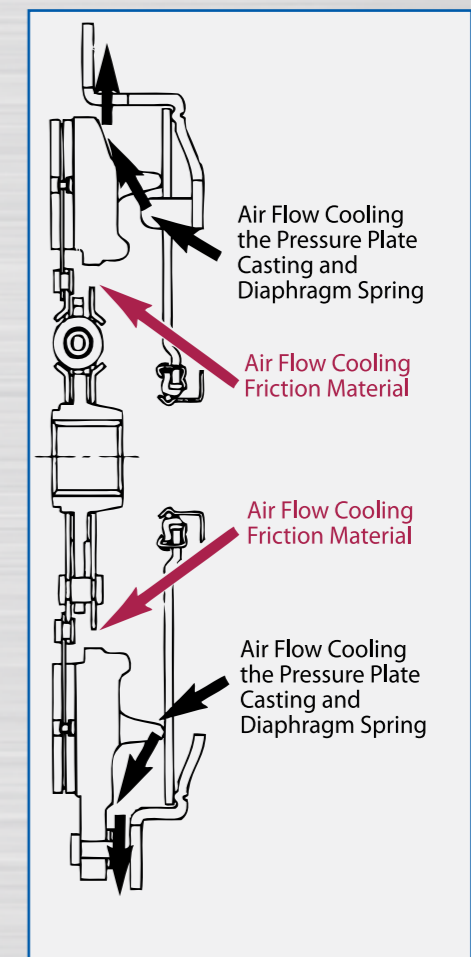
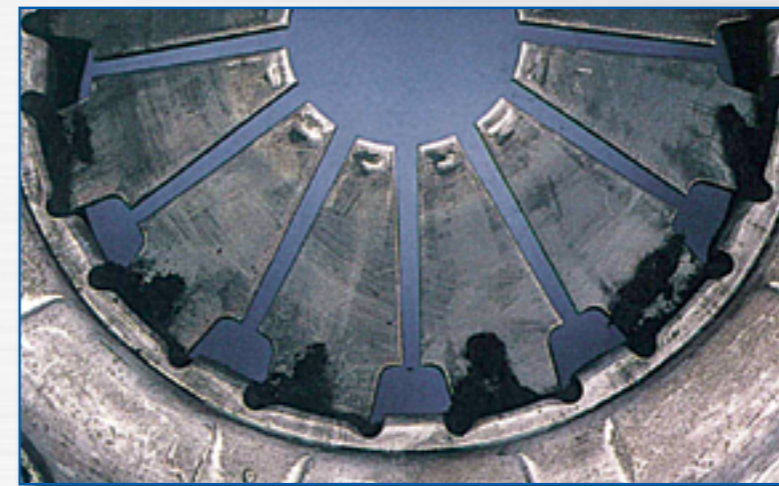

**PROBLEM:** Worn clutch disc facing fibres and dirt lodged between diaphragm spring and clutch cover housing, causing loss of clamp load

**SYMPTOM:** Slipping clutch and clutch drag

**CAUSE:** 1. Bell housing not degreased and cleaned. Careless installation of new clutch  
 The new clutch disc has not worn but the fibres that have become lodged in the new clutch cover are that of the previously worn clutch. It is a requirement due to ventilation designs that the bell housing area be free from old fibres, dirt and grease when installing a new clutch

2. This problem is common in 4 wheel drive vehicles when an inspection cover or a clutch fork cover boot has not been replaced when installing a new clutch

**SOLUTION:** 1. Ensure bell housing is thoroughly degreased and clean of dirt and fibres before installing new clutch

2. Ensure inspection locations and boots are replaced, tightened and well located

*Note: These problems are common on farm vehicles, vehicles travelling on sand and 4x4 recreational vehicles.*

**PROBLEM:** 1. Installation assist clips not removed  
 2. Slipping clutch/excessive free travel  
 3. Unable to adjust  
 4. Will not transmit power

**SYMPTOM:** Clutch slipping just after installing new clutch

**CAUSE:** Clutch cover pressure plate assembly hold down clips (to assist ease of installation) have not been removed

**SOLUTION:** Remove clips after installation

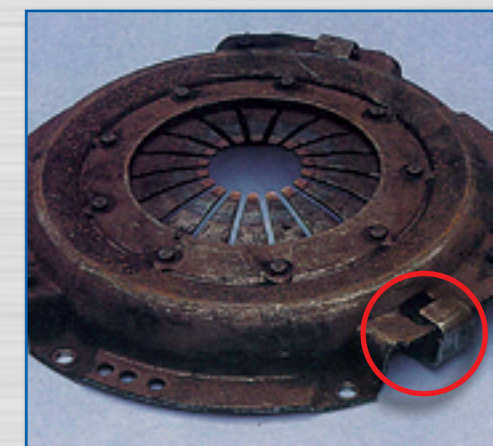



**PROBLEM:** No clutch adjustment (diaphragm over centre/ clutch disc side plate fouling)

**SYMPTOM:** 1. Diaphragm over centre when bolting clutch cover pressure plate assembly to flywheel  
2. Clutch disc side plate fouls on I.D. of casting

**CAUSE:** Careless mechanical fitting practices

**SOLUTION:** Always mate the clutch disc to the pressure plate casting and flywheel to ensure no fouling occurs before installing a new clutch

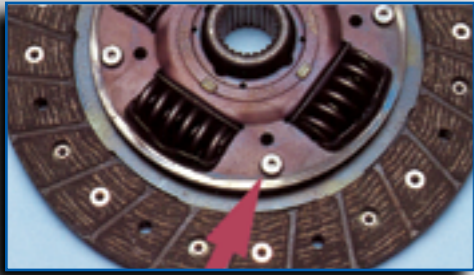

**PROBLEM:** Stretched/damaged retractor clip above the diaphragm

**SYMPTOM:** Difficult engagement/disengagement after installation of new clutch

**CAUSE:** Over adjustment of clutch that has caused stretching of retractor clips on clutch cover pressure plate assembly

**SOLUTION:** 1. Fit new cover assembly  
2. Adjust clutch to manufacturer's specifications

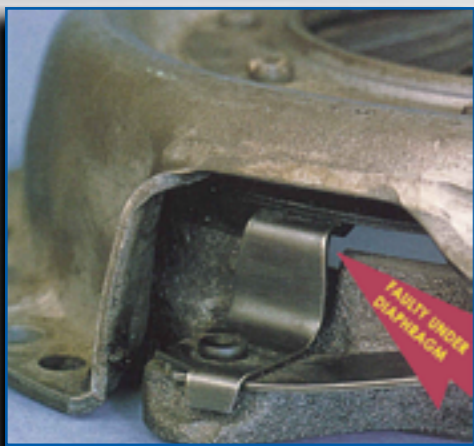

**PROBLEM:** Stretched/damaged retractor clip underneath diaphragm

**SYMPTOM:** Difficult engagement/disengagement after installation of new clutch

**CAUSE:** Clutch cover pressure plate assembly has been dropped during installation/or during transit causing damage to retractor clips

**SOLUTION:** Always check the components before fitting and ensure the tip of the retractor clip is resting on top of the diaphragm. This can be checked using a feeler gauge.

*(This is the installer's responsibility).*

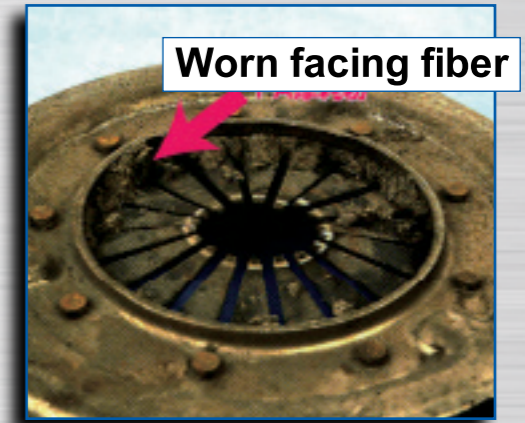

Worn facing fibers and dirt lodged

**PROBLEM:** Worn clutch disc facing fibers and dirt lodged between diaphragm spring and clutch cover housing

**SYMPTOM:** Difficult to disengage gear/ Slipping clutch

**CAUSE:** Bell housing not degreased and cleaned  
Careless installation of new clutch

**SOLUTION:** Ensure bell housing is thoroughly degreased and clean of dirt and fibers before installing new clutch

**PROBLEM:** Bearing retainer clip not connected to diaphragm

**SYMPTOM:** No pressure on clutch pedal - new pull type clutch just installed

**CAUSE:** Proper installation procedures have not been followed. The snap-in mechanism of the release bearing has not been clipped on firmly

**SOLUTION:** When the transmission is installed onto the mating area of the engine the release bearing is preliminarily set into position where the release fork of the transmission is fitted

After installation of the transmission, the release lever must be pulled in the reverse direction to secure the release bearing to the retaining mechanism. The bearing is then snapped in. (Also refer to manufacturer's specifications)

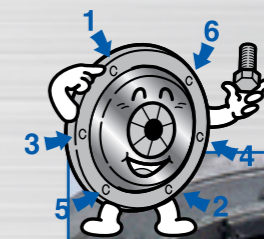
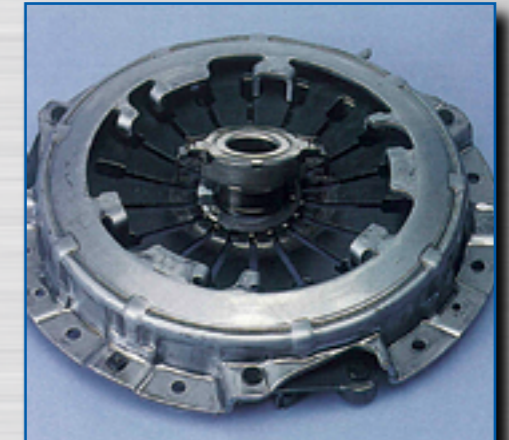

**PROBLEM:** Clutch diaphragm fingers or levers are uneven

**SYMPTOM:** Clutch drag and pedal vibration

**CAUSE:** 1. The pressure plate cover assembly was torqued down incorrectly i.e. not diagonally  
2. The pressure plate cover assembly was torqued down with an air wrench

**SOLUTION:** 1. Never use air tools to torque down a clutch

\*Refer to page 57 for proper tightening specifications

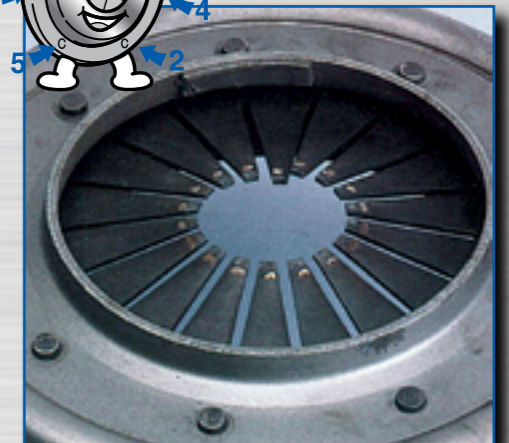

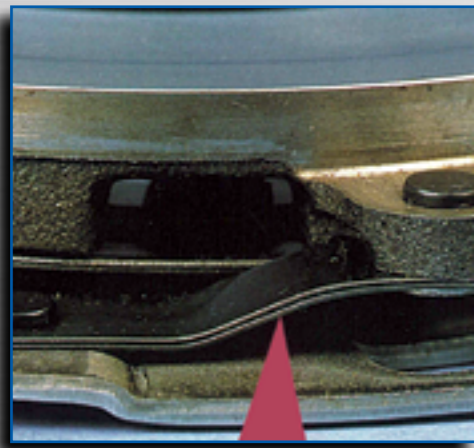

- PROBLEM:** Bent drive straps
- SYMPTOM:** No disengagement
- CAUSE:**
1. Improper driving practice
  2. Distorted retractor leaf spring caused by extreme reverse thrust load spring
  3. Sudden down changing of gears i.e. 5th gear to 2nd gear
  4. Wrong clutch cover assembly used due to engine turning direction
  5. Constant "dropping" of clutch at extremely high revs when taking off
- SOLUTION:**
1. Driver education
  2. Install correct cover assembly for the application
  3. Fit extra straps to suit heavy duty application (optional), or use EXEDY Sports clutch

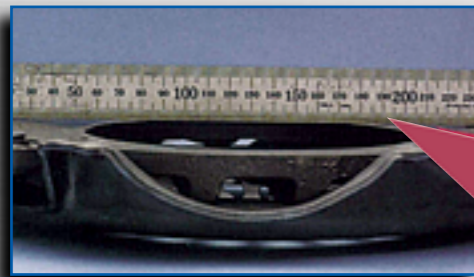

- PROBLEM:** Warped clutch cover pressure plate assembly casting
- SYMPTOM:** Clutch drag/No disengagement
- CAUSE:** Only clutch disc was replaced which caused a vacuum, not allowing the clutch disc to separate from the clutch cover pressure plate assembly casting (when clutch is in disengaged position)
- SOLUTION:** Always replace clutch disc/clutch cover pressure plate assembly and clutch thrust/release bearing when replacing clutch system



- PROBLEM:** Broken ears on pull type release bearing (Subaru)
- SYMPTOM:** Difficulty engaging or disengaging gears
- CAUSE:** Interference from wiring loom during installation can apply undue force to clutch fork and release bearing, resulting in breakage of bearing ears
- SOLUTION:** Use caution when re-installing transmission to avoid interference from the wiring loom

- PROBLEM:** Unable to select gear and unable to stop rotation of main drive shaft
- SYMPTOM:** Clutch brake not operating (large pull type clutch)
- CAUSE:**
1. Wear on fingers of the clutch release yoke mechanism (which includes cross shaft bushings)
  2. Excessive wear on bearing housing head fork saddle
- SOLUTION:**
1. Replace all worn bushings in relation to release lever mechanism
  2. Replace bearing head assembly
  3. Readjust to the manufacturer's specification

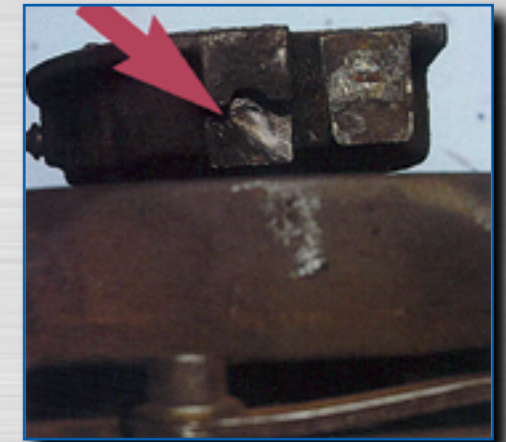

- PROBLEM:** Jammed, Leaking or completely destroyed Concentric Slave Cylinder (CSC)
- SYMPTOM:** Slipping clutch. Difficult to disengage gears
- CAUSE:**
- Slipping clutch:**  
Over stroking or excessive preload of the cylinder due to incorrect release mechanism adjustment or blockage in the hydraulic line limiting return fluid flow back to the master cylinder

**Difficult to disengage gears:**

- a. Air in system due to incorrect hydraulic bleeding procedure
- b. Fluid contamination resulted in premature failure of the cylinders internal piston seal
- c. Blockage in the hydraulic line has resulted in complete cylinder failure
- d. Mounting surface on front of transmission not cleaned prior to fitment of cylinder, preventing o-ring seal properly

- SOLUTION:**
1. Always flush the hydraulic system and only use new hydraulic fluid when fitting a new cylinder. Adjust release mechanism to the manufacturer's specifications. Replace faulty hydraulic components (master cylinder, dampening valves, hydraulic lines etc)

- 2a. Adjust release mechanism to the manufacturer's specifications
- 2b. Always flush the hydraulic system and only use new hydraulic fluid when fitting a new cylinder
- 2c. Replace faulty hydraulic components (master cylinder, dampening valves, hydraulic lines etc).
- 2d. Always ensure the mounting surface is clean and the o-ring seal (where required) is used to provide a positive seal



Malfunction of cylinder assembly



**PROBLEM:** Damaged pilot bushing

**SYMPTOM:** Difficulty engaging or disengaging gears. Noisy clutch

**CAUSE:** Improper installation practices. Forcing the input shaft/transmission on crank bushing engine block

**SOLUTION:**

1. Align the transmission to the crank/engine block during installation. Never force transmission to the engine
2. Do not use bell housing bolts to force the transmission onto the engine block
3. Proper installation practices



Deteriorated pilot bearing

**PROBLEM:** Notchy pilot bearing

**SYMPTOM:** Difficulty engaging or disengaging gears. Noisy clutch

**CAUSE:** Reuse of pilot bearing

**Noise:** Reuse of deteriorated pilot bearing may cause abnormal noise from the bearing under depressing clutch pedal condition

**Difficult to disengage gear:** Reuse of bearing which is not smooth movement causes difficult to disengage gear, because it transmits torque under disengagement condition

**SOLUTION:** Always replace with new pilot bearing when you replace the clutch



**PROBLEM:** Excessive score marks on clutch thrust bearing

**SYMPTOM:** Excessive free travel/clutch does not disengage/ noisy - Japanese range of trucks

**CAUSE:**

1. Incorrect fitment of clutch thrust bearing to the clutch release fork causing the carrier to spin off the fork tips and bearing carrier saddle
2. Insufficient bearing retainer clip tension

**SOLUTION:**

1. Care should be taken to ensure bearing carrier is secured to the release fork properly
2. Always work thrust bearing forwards and backwards to check the retaining clip provides sufficient tension

**PROBLEM:** Broken saddle clip

**SYMPTOM:** Noisy rattle and difficult to engage gear

**CAUSE:** Careless installation as spring retaining clip not assembled to fork during installation, or tension on wire retaining clip not correct

**SOLUTION:**

1. Check tension on wire retaining clip
2. Always check the bearing on the clutch release fork after installation. Move the fork in both directions to ensure the bearing is secure before re-fitting the gearbox



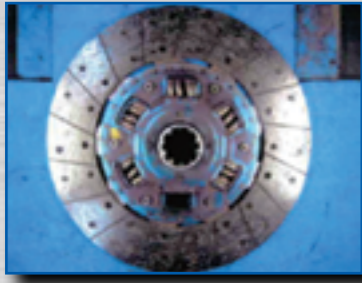

**PROBLEM:** Damaged torsion springs  
**SYMPTOM:** Unable to disengage gears/Noisy clutch  
**CAUSE**  
 1. When engine torque is higher than clutch torque, this misapplication causes springs to deteriorate  
 2. Mis-alignment between the crankshaft and the transmission mainshaft causes this problem during installation of the transmission  
**SOLUTION:** 1. Select and fit the appropriate EXEDY clutch kit to suit the application  
 2. Replace deteriorated pilot bearing, bush, missing or damaged dowels and remove any contamination or burrs from mating surfaces between the engine and transmission



**PROBLEM:** Broken facings  
**SYMPTOM:** Slipping clutch/Shudder/Judder/Noisy clutch. Unable to drive  
**CAUSE:** Following factors lead to high temperature of friction surface, resulting in this problem  
 1. Driving with a foot on the clutch pedal  
 2. Overloading vehicle  
 3. Improper starting gear  
 4. Clutch pedal height or free play maladjustment  
 5. Oil/grease contamination  
**SOLUTION:** 1.~ 3. Driver education  
 4. Adjust pedal free play according to the service manual



\*Do not over grease input shaft or disc during installation

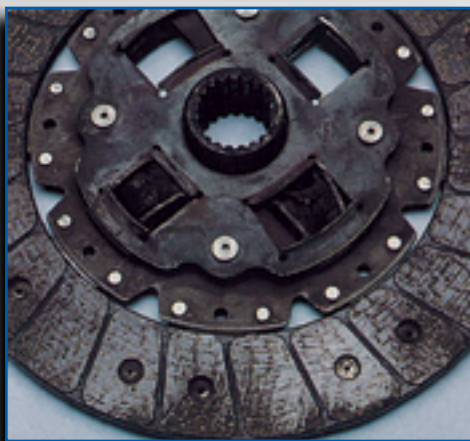

**PROBLEM:** Broken rubber dampeners  
**SYMPTOM:** Noisy/No disengagement (rubber torque stopper type clutch disc)  
**CAUSE:**  
 1. Use of inferior or imitation clutch disc  
 2. Clutch wound past torque capacity  
 3. Inferior rubber compound  
**SOLUTION:** 1. Fit genuine EXEDY clutch  
 2. Driver education

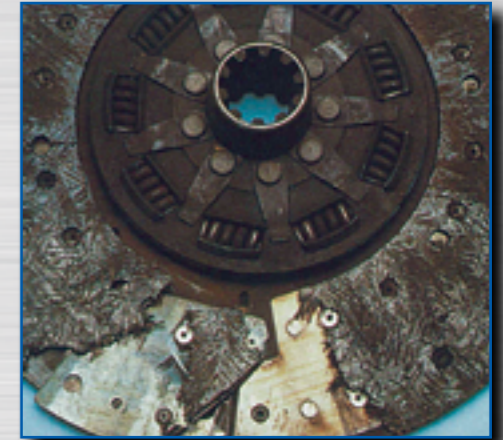

**PROBLEM:** Broken facing material on the clutch disc  
**SYMPTOM:** No drive/Noisy clutch  
**CAUSE:** Parts of the disc friction material are broken from the rivet along with part of the cushioned segment. This is due to down shifting of gear i.e. the speed of the vehicle at the rear wheels was travelling faster than the engine RPM, when gear was changed down  
**SOLUTION:** Driver education

**PROBLEM:** Broken segments on the clutch disc/Sprung hub separated from facings  
**SYMPTOM:** Sudden clutch failure/No drive/Noisy clutch  
**CAUSE:** Cushion spring steel segments uniformly separated from hub area due to:  
 1. Faulty or worn pilot bearing or bushing  
 2. Hanging gearbox during installation  
 3. Dirt or chips between the mating surfaces of the engine bolt up areas  
 4. Gearbox/transmission lock up. (i.e. Gear tooth jam)  
**SOLUTION:** 1. Check pilot bushing or bearing and replace if necessary. Align gearbox and use the assistance of a transmission jack and always clean mating surfaces before installation  
 2. Check gearbox for metal fragments then remove and repair as necessary



**PROBLEM:** Broken facing of clutch disc on clutch cover assembly, pressure plate side  
**SYMPTOM:** Noisy clutch/Slipping clutch  
**CAUSE:**  
 1. Improper driving practice; down changing gear constantly  
 2. The speed of the vehicle is actually higher than of the shifted to gear  
 3. The gearbox and drivetrain revolutions are turning faster than the speed of the engine at the time: sudden clamp damaged the facings  
 4. Excessive grease on the transmission input shaft  
**SOLUTION:** 1. Driver education  
 2. Proper fitting practice

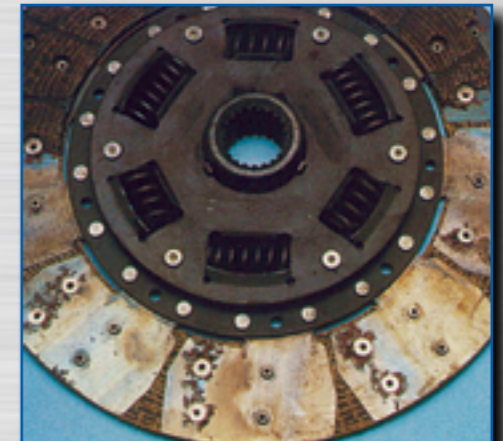

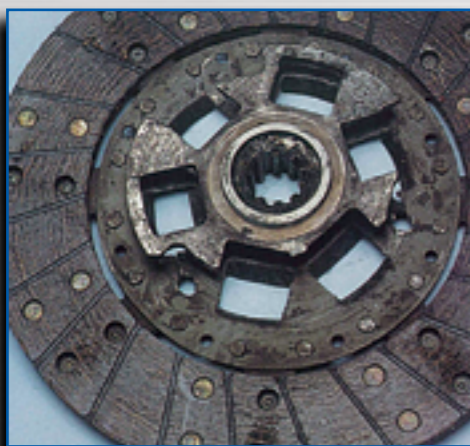

**PROBLEM:** Clutch disc completely ruined  
**SYMPTOM:** Sudden clutch failure  
**CAUSE:** Clutch disc fitted incorrectly i.e. back to front  
**SOLUTION:** Always check clutch disc on flywheel for fouling before installation

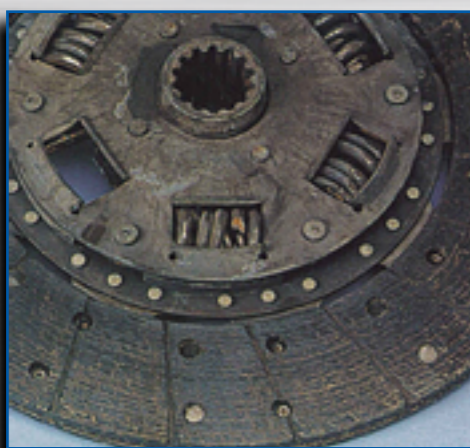

**PROBLEM:** Damaged torsion springs  
**SYMPTOM:** Gearbox rattle/noisy clutch - diesel applications. Other descriptions of problem are: gearbox rollover noise or tick over noise  
**CAUSE:** When engine torque is higher than clutch torque this causes springs to deteriorate. This is due to the very different characteristics in design of this particular clutch disc  
**SOLUTION:** Choose and fit the appropriate EXEDY clutch to suit this application (e.g. silent type design or LTD design)



**PROBLEM:** Splines completely disintegrated on the clutch disc  
**SYMPTOM:** No drive/Noisy clutch  
**CAUSE:** 1. Clutch disc not tested on spline before installation  
 2. Missing spigot/pilot bearing or bushing  
**SOLUTION:** 1. Always check the number of splines on the clutch disc match those on the transmission input shaft and that the disc slides smoothly onto the input shaft prior to installation  
 2. Check and replace spigot/pilot bearing of bushing. (Mini UK and Europe: Check primary gear for worn bushing; if worn replace)

**PROBLEM:** Torsion dampener stopper springs thrown out of side plate/stop pins worn

**SYMPTOM:** Noisy clutch/Unable to engage or disengage gear

**CAUSE:** 1. Improper driving practice i.e. "dropping" the clutch whilst engine is turning at extremely high revolutions  
 2. Down changing of gears i.e. 5th gear to 2nd gear by low speed/high driving gear method  
 3. Wear on the stop pins indicates the clutch plate has been wound past specified torque loading. This has the same effect on the springs  
 4. Misalignment

**SOLUTION:** 1. Driver education  
 2. Refer misalignment tips on page 56  
 3. Vehicle used for performance driving. It is advisable to use clutch disc with higher stopper torque capacity. Refer to EXEDY Performance/ Sports Clutch listings

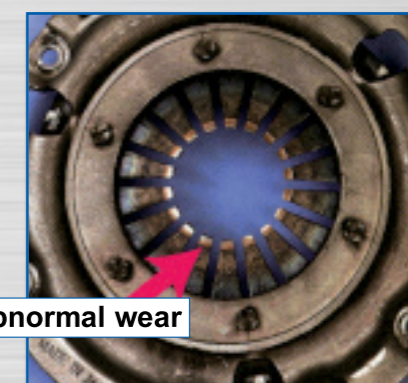

**PROBLEM:** Excessive wear on diaphragm tips

**SYMPTOM:** Difficult to disengage gear/ Noisy clutch

**CAUSE:** Driveline misalignment. Wear to both the diaphragm levers and inside fulcrum of the clutch cover result in less pressure plate lift and difficulty in engaging gears

**SOLUTION:** Refer to misalignment tips on page 56

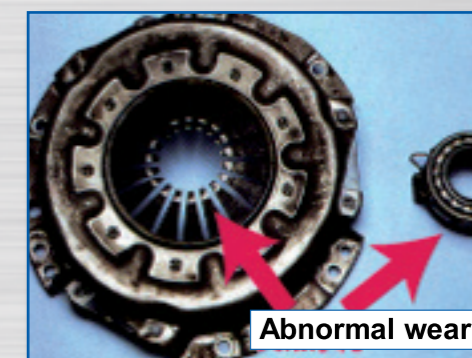

Excessive wear on diaphragm tips

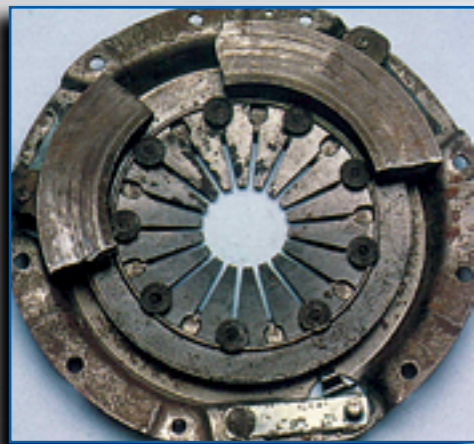

**PROBLEM:** Burst pressure plate casting

**SYMPTOM:** No disengagement

**CAUSE:**

1. Over revving of engine that has exceeded vehicle manufacturer's specifications.
2. Over heating of casting due to constant abuse of clutch. The main spring has weakened through extreme influence of heat

**SOLUTION:**

1. Driver education
2. Do not use EXEDY covers where engine has been modified to exceed manufacturer's RPM specifications
3. Use EXEDY specified sports clutch. Refer to EXEDY Standard range or EXEDY Sports listings where covers are manufactured with nodular iron castings

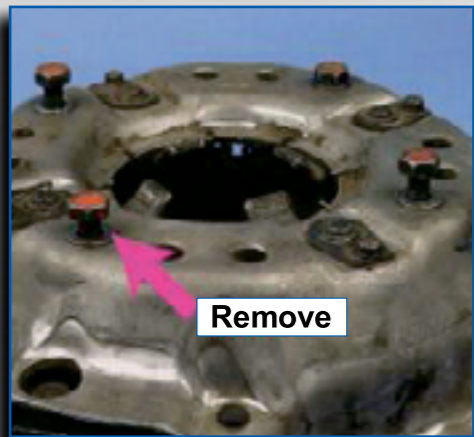

Remove hold down bolts

**PROBLEM:** Hold down bolts still in cover assembly

**SYMPTOM:** Clutch slipping/Noisy clutch

**CAUSE:** Clutch cover pressure plate assembly hold down bolts (to assist/ease installation) not removed

**SOLUTION:** Remove hold down bolts painted in red. (Do not remove clutch lever adjustment nuts which are not painted in red)

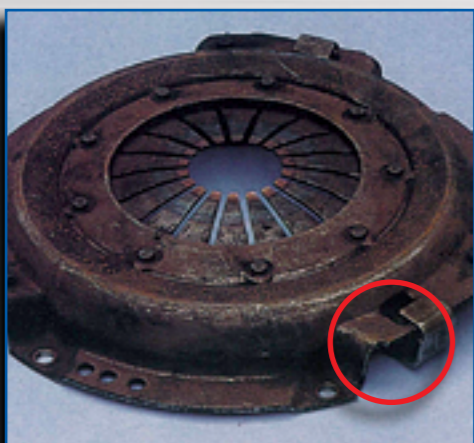

**PROBLEM:**

1. Installation assist clips not removed
2. Slipping clutch/excessive free travel
3. Unable to adjust
4. Will not transmit power

**SYMPTOM:** Clutch slipping just after installing new clutch

**CAUSE:** Clutch cover pressure plate assembly hold down clips (to assist ease of installation) have not been removed

**SOLUTION:** Remove clips after installation.

**PROBLEM:** Worn rubber absorber tips where clutch fork contacts release bearing

**SYMPTOM:** Clutch fork rattle whilst idling

**CAUSE:**

1. Some clutch thrust bearing carriers are held firmly by an absorber rubber bush that wears over time
2. Clutch thrust bearing carrier saddle worn

**SOLUTION:**

1. Rectify by fitting new absorber rubber bush to prevent the fork dropping against the bell housing window
2. Always check for wear on clutch thrust bearing carrier saddle. Replace if necessary

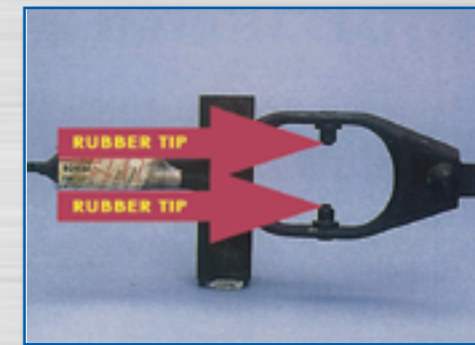

**PROBLEM:** Excessively worn diaphragm spring

**SYMPTOM:** Noisy clutch thrust/release bearing/high pitched squeal

**CAUSE:** Clutch thrust bearing fitted incorrectly e.g. back to front

**SOLUTION:** Replace with new bearing fitted correctly i.e. right way around

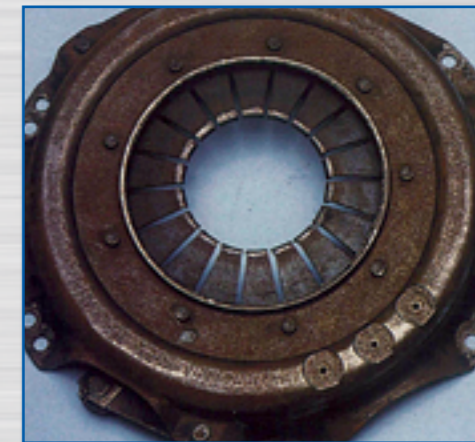

**PROBLEM:** Damaged clutch/thrust release bearing

**SYMPTOM:** Noisy clutch thrust/release bearing after fitting new clutch kit/High pitched squeal

**CAUSE:** Bearing fitted incorrectly

**SOLUTION:** Fit new clutch thrust bearing the right way around

*Note: Ensure cover pressure plate assembly diaphragm has not been damaged from previous clutch thrust bearing*



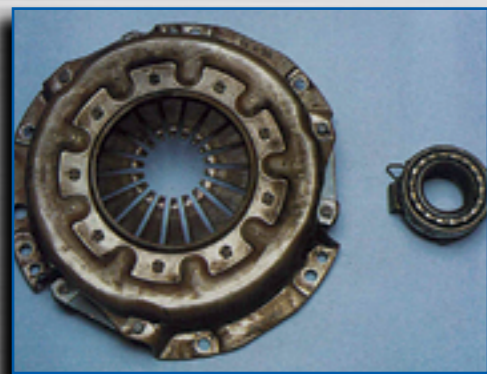

**PROBLEM:** Damaged clutch thrust bearing. Diaphragm spring excessively worn

**SYMPTOM:** Continuous clutch thrust bearing noise

**CAUSE:** The clutch has not been adjusted correctly since installation or the clutch has never been adjusted during any routine service. The clutch thrust bearing and the diaphragm of the clutch cover pressure plate assembly have worn indentations into each other

**SOLUTION:** 1. Fit new clutch kit as it is too late for adjustment of old clutch  
2. Always check free travel at service

**PROBLEM:** Excessive score marks on clutch thrust bearing

**SYMPTOM:** Excessive free travel/clutch does not disengage/ Noisy - Japanese range of trucks

**CAUSE:** 1. Incorrect fitment of clutch thrust bearing to the clutch release fork causing the carrier to spin off the fork tips and bearing carrier saddle  
2. Insufficient bearing retainer clip tension

**SOLUTION:** 1. Care should be taken to ensure bearing carrier is secured to the release fork properly  
2. Always work thrust bearing forwards and backwards to check the retaining clip provides sufficient tension



**PROBLEM:** Damaged pilot bushing

**SYMPTOM:** Difficulty engaging or disengaging gears/Noisy clutch

**CAUSE:** Improper installation practices. Forcing the input shaft/transmission on crank bushing engine block

**SOLUTION:** 1. Align the transmission to the crank/engine block during installation. Never force transmission to the engine  
2. Do not use bell housing bolts to force the transmission onto the engine block  
3. Proper installation practices

**PROBLEM:** Broken saddle clip

**SYMPTOM:** Noisy rattle and difficult to engage gear

**CAUSE:** Careless installation as spring retaining clip not assembled to fork during installation, or tension on wire retaining clip not correct

**SOLUTION:** 1. Check tension on wire retaining clip  
2. Always check bearing on clutch release fork after installing the bearing on it. Move the fork in both directions to ensure bearing is secure before refitting gearbox



Deteriorated pilot bearing

**PROBLEM:** Notchy pilot bearing

**SYMPTOM:** Difficulty engaging or disengaging gears/Noisy clutch

**CAUSE:** Reuse of pilot bearing

**Noise:**

Reuse of deteriorated pilot bearing may cause abnormal noise from the bearing under depressing clutch pedal condition

**Difficult to disengage gear:**

Reuse of bearing which is not smooth movement causes difficult to disengage gear, because it transmits torque under disengagement condition

**SOLUTION:** Always replace with a new pilot bearing when you replace the clutch

**PROBLEM:** Torque stopper springs broken

**SYMPTOM:** Noisy clutch with vibration

**CAUSE:** 1. Misalignment between engine crank-shaft centre and gearbox main shaft  
2. If the torsion springs are damaged along with the torque stopper pin then it is evident that the clutch has been wound past its torque capacity

**SOLUTION:** 1. Refer misalignment tips on page 56  
2. Driver education





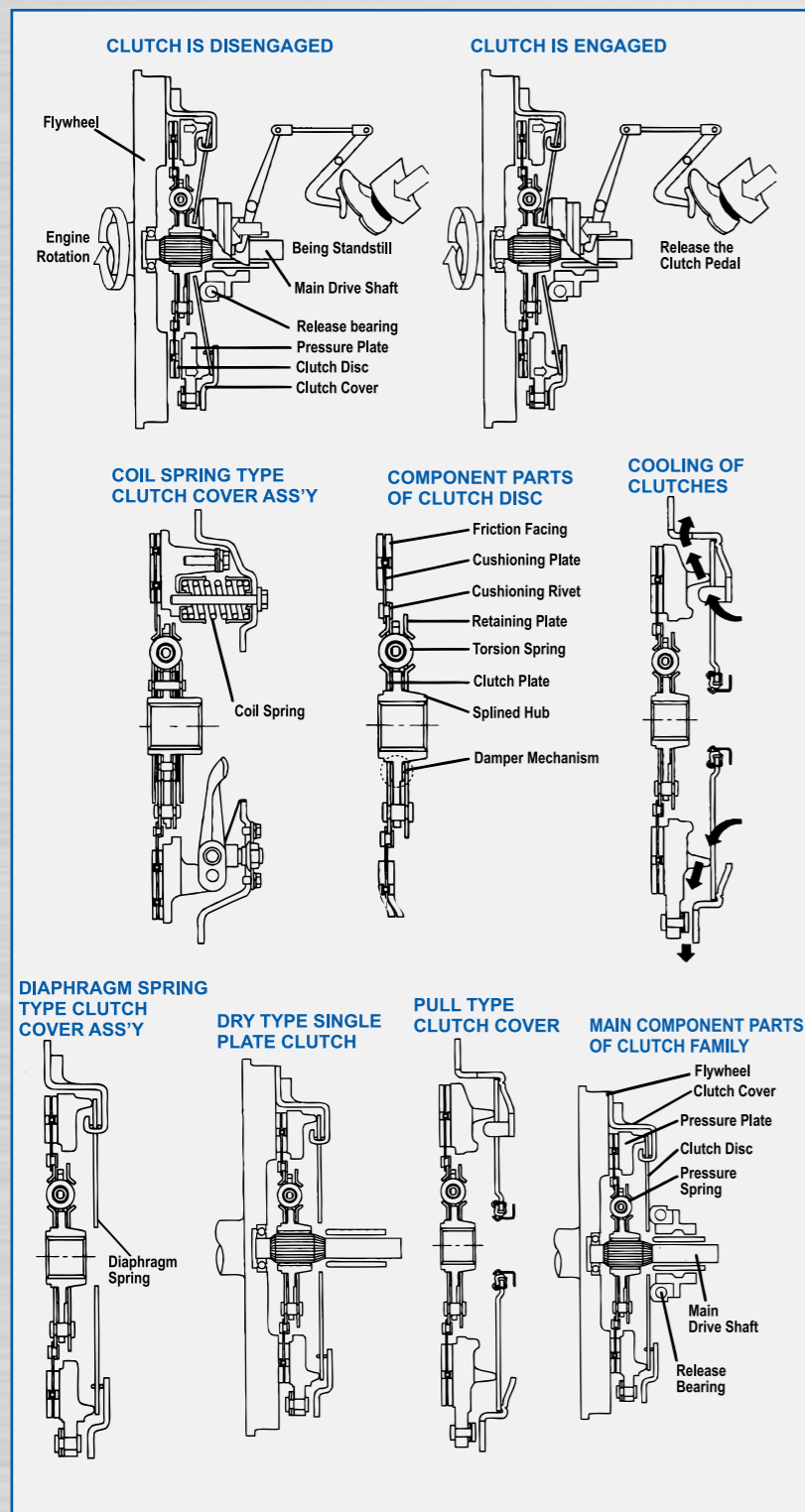

### 1. Clutch release bearing

- A. Depress the clutch pedal approximately 2". The bearing is now in contact with the diaphragm. Should the bearing rumble or squeal then the clutch release bearing is most likely at fault (providing it has been pressed onto the carrier the right way around)

### 2. Pilot Bearing or Bush.

- A. With engine running depress the clutch fully
  - B. Select first gear
  - C. Release the clutch
- If the squeal is heard at the point of the clutch taking up then the pilot bearing is faulty. In the event it is a bronze bush, it will indicate lack of lubrication on the I.D. of the bush. If the bush has been lubricated on the I.D. there is a greater possibility that the O.D. of the bush is under sized and worn. The noise is then caused by the bush spinning in the end of the crank. The new pilot bush has not been pressed in evenly this could also result in the bush spinning which would cause a grumbling or squealing noise. Pilot bush noises are more apparent when engine and transmission are cold. (i.e. In the morning)

### 3. Front gearbox bearing

- A. Drive the vehicle at approximately 30 kilometers per hour in gear. If a noticeable grumble noise is apparent, depress the clutch pedal. This will, in turn, stop the main drive and bearing from spinning. If noise ceases it is probable that the front gearbox bearing is faulty (as there is no load on the bearing)

**PROBLEM:** Excessively worn diaphragm fingers

**SYMPTOM:** Pedal graunch sometimes described as erratic feeling when depressing clutch pedal with engine running but OK when not running/ Notchy clutch pedal

- CAUSE:**
1. Eccentricity between the axis of rotation of the clutch cover pressure plate assembly and that of the clutch thrust bearing
  2. Inferior clutch thrust bearing (not self centering type)
  3. Worn release bearing sleeve carrier or clutch fork
  4. Lack of free travel

- SOLUTION:**
1. Refer misalignment tips on page 56
  2. Fit proper self centering bearing
  3. Rectify release mechanism and align
  4. Adjust free travel to manufacturer's specification

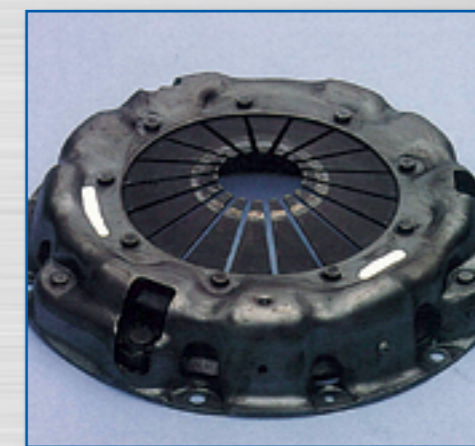

**PROBLEM:** Bearing retainer clip not connected to diaphragm

**SYMPTOM:** No pressure on clutch pedal - new pull type clutch just installed

**CAUSE:** Proper installation procedures have not been followed. The snap-in mechanism of the release bearing has not been clipped on firmly

**SOLUTION:** When the transmission is installed onto the mating area of the engine the release bearing is preliminarily set into position where the release fork of the transmission is fitted. After installation of the transmission, the release lever must be pulled in the reverse direction to secure the release bearing to the retaining mechanism. The bearing is then snapped in. (Also refer to manufacturer's specifications)



**PROBLEM:** Clutch diaphragm fingers or levers are uneven

**SYMPTOM:** Clutch drag/Pedal vibration

**CAUSE:**

1. The pressure plate cover assembly was torqued down incorrectly i.e. not diagonally
2. The pressure plate cover assembly was torqued down with an air wrench

**SOLUTION:**

1. Refer to page 57 for proper tightening specifications.
2. Never use air tools to torque down a clutch

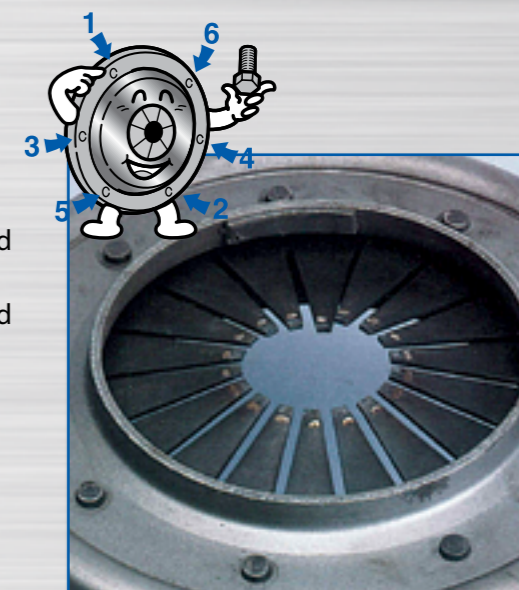



Notchy wear on front cover

**PROBLEM:** Abnormal wear on the release bearing guide tube  
**SYMPTOM:** Sticky or notchy pedal/Slipping clutch  
**CAUSE:** Driveline misalignment. No grease applied to guide tube  
**SOLUTION:** Refer misalignment tips on page 56. Apply appropriate grease. Renew worn parts



**PROBLEM:** Worn clutch thrust bearing carrier  
**SYMPTOM:** Pulsating pedal with engine running  
**CAUSE:** Faulty installation as the clutch thrust bearing carrier is worn on the saddle where the fork pivots. This also reduces the tension on the wear clip retainer. In this case, due to the lack of tension, the fork has become dislodged and scored the back of the bearing  
**SOLUTION:** Always replace worn clutch thrust bearings, carriers and worn forks

---

---

---

---

---

---

---

---

---

---

---

---

---

---

---

---

---

---

---

---

---

---

---

---

---

---

---

---

---

---

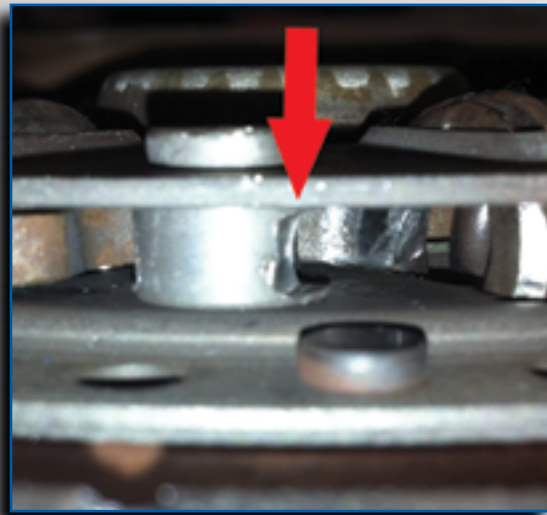

**PROBLEM:** Noise/Difficulty engaging gears  
**CAUSE:** Broken drive hub on clutch disc. Damaged stop pin from high RPM clutch "dumping" or "side skipping" from a stop  
**SOLUTION:** Driver education, change driving style

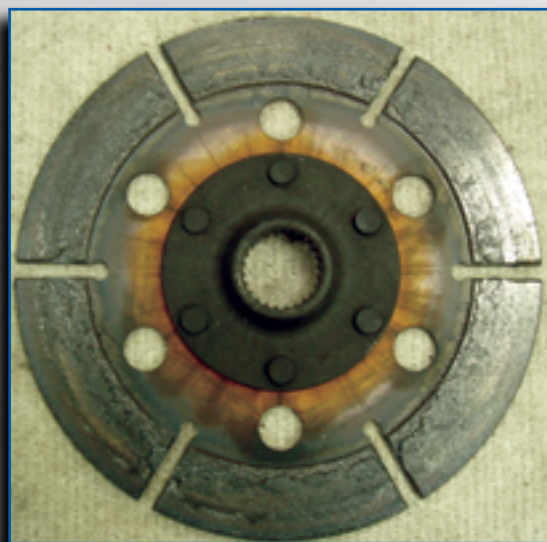

**PROBLEM:** Clutch slippage  
**CAUSE:** Over greasing the input shaft  
**SOLUTION:** Use a thin coating of grease, uniform and evenly, on input shaft  
**TECH TIP:** Slide clutch disc on to input shaft to evenly distribute grease on spline. Wipe away all excess grease from end of spline and disc. Be careful not to touch the facing of disc with grease

**PROBLEM:** Difficulty changing gears  
**CAUSE:** Intermediate plate not in the correct location on the flywheel  
**SOLUTION:** Always line up the blue marks on all the components during installation  
**TECH TIP:** A center punch can be used to leave an indentation on each component as the paint can be affected by chemicals

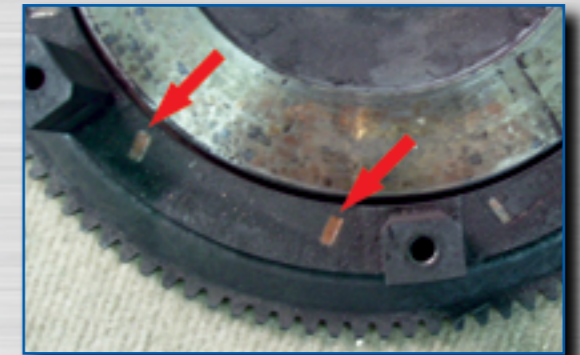

**PROBLEM:** Gearbox noise/Difficulty changing gears  
**CAUSE:** Damaged spline hub and disc due to one or more of the following:

1. Inadequate lubrication on input shaft
2. Burrs on input shaft of transmission not allowing hub to slide freely
3. Too much pressure plate left from improperly adjusted pedal stop or hydraulic assembly
4. Bad input shaft bearing, pilot bearing or pilot bushing causing hub to wobble against discs

**SOLUTION:**

1. Use proper lubrication on input shaft
2. Inspect input shaft on transmission for burrs or damage
3. Properly adjust pedal stop and/or hydraulic assembly
4. Measure input shaft in play, inspect pilot bearing/bushing



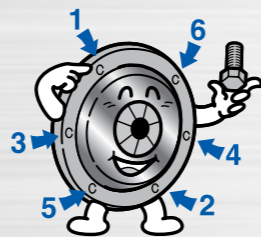

**PROBLEM:** Clutch slippage "slipping"  
**CAUSE:** Loose cover assembly bolts from improper bolt tightening torque procedure  
**SOLUTION:** Use manufacturer's bolt torque specs. Tighten evenly. Use thread locker to ensure bolts do not loosen

*Refer to page 57 for proper tightening specifications*

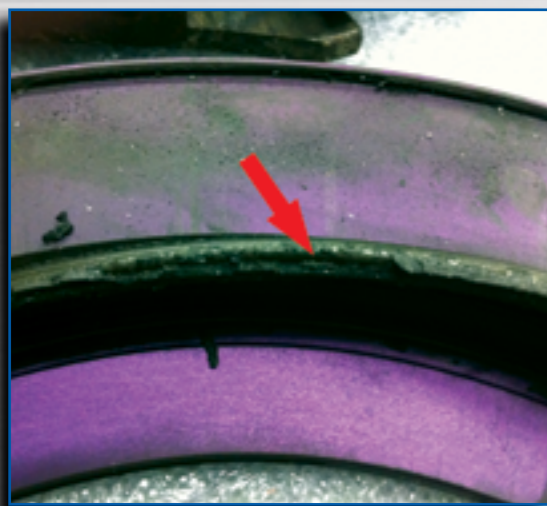

**PROBLEM:** Difficulty changing gears/No release.  
**CAUSE:** Debris built up in pivot ring area between cover and diaphragm spring.  
**SOLUTION:** Disassemble cover assembly and clean thoroughly.

**PROBLEM:** Difficulty changing gears  
**CAUSE:** Mis-shift at high RPM or aggressive down shifting at high RPM  
**SOLUTION:** Driver education, Change driving style, use lug type multi plate clutch



**PROBLEM:** Chipped facing  
**CAUSE:** Improper break in of clutch assembly  
**SOLUTION:** Follow manufacturer's break in procedures



**PROBLEM:** Difficulty changing gears  
**CAUSE:** Spline damage on the bottom disc(s) from not being aligned properly  
**SOLUTION:** Use the proper alignment tool for vehicle application  
**TECH TIP:** Twist the alignment tool to align the bottom discs while finger tightening the cover bolts



## Driveline Misalignment in General/Tips

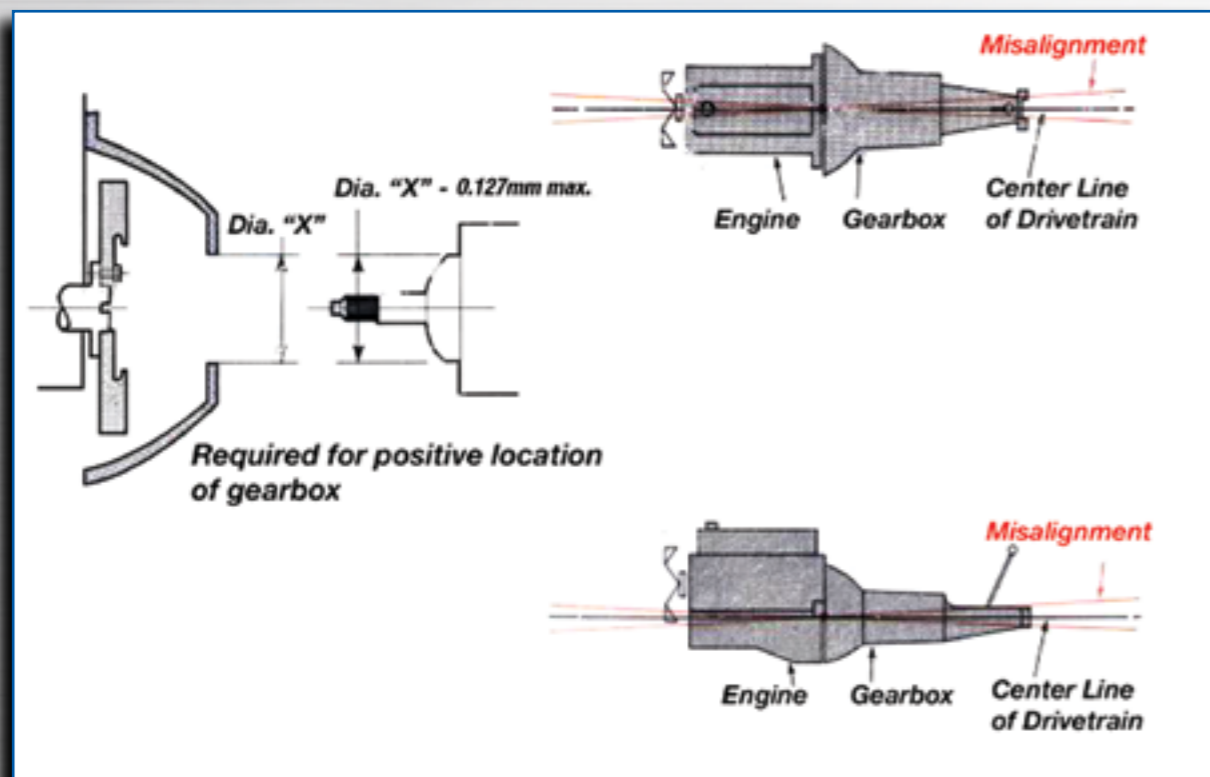

1. Warped alloy bell housing
2. Tubular dowel pin guides crushed during fitting of bell housing to mating dowel pin hole and/or missing dowel pins.
3. Worn gearbox quill/gearbox main drive nose cone bearing slide: causing bearing to come in contact with the diaphragm of cover assembly off centre line whilst actuating clutch.
4. Dirt-chips-wiring harness clips-hydraulic pipe clamp clips – thick grease build up interfering between the mating surface of the gearbox bell housing and motor.
5. Worn Spigot bushes and pilot bearings along with front gearbox main bearings to be checked for wear.
6. Exchange engines and gearboxes have missing dowel pins. Ensure you remove pins from your product when you send your core for remanufacture and refit when installing the new clutch.

## Flywheels and pressure plates need to be torqued down to proper specifications

The reason why these components need to be torqued down to a specific value is to ensure that the components do not loosen up and function improperly. The clutch and flywheel spin to thousands of RPM's and have varied harmonics sent through them by the engine and drivetrain.

When one side has a greater torque value combined with centrifugal force and harmonic vibrations it allows the opposing side with a lesser torque value to loosen up. Improper torque is the number one reason for a given rotating component to become loose whether it is a wheel and tire or a flywheel. For these reasons it is imperative to torque to proper specifications.

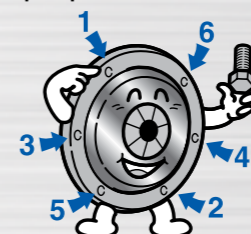

When tightening flywheel or pressure plate bolts you should tighten each bolt a little bit at a time using a star pattern to tighten. This ensures that each bolt receives an equal torque value. When tightening bolts that require a specific torque value NEVER use power tools such as impact guns or air tools. When tightening bolts use a calibrated torque wrench to ensure the proper torque is being applied evenly to the specific bolts. ALWAYS refer to the vehicles factory service manual for proper torque specifications for a given bolt or component.

The use of thread locker or Loctite on each flywheel bolt and pressure plate bolt gives added insurance to avoid bolts backing out resulting in damage to the vehicle and its components. Damage to the crank and transmission may occur when bolts back out due to balance being thrown off and or contact damage of components that have loosened up.

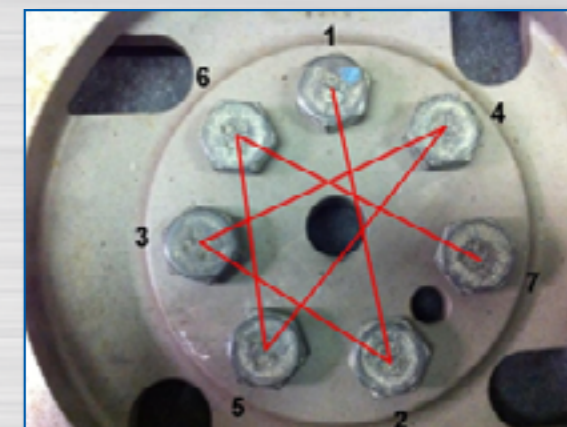

# MAKE SURE YOU ARE USING THE REAL DEAL



## + WHY EXEDY?

- ▶ High clamp loads to cope with heavy loads
- ▶ Diaphragms manufactured using high carbon (SD70c) steel and induction hardened finger tips = reduction in diaphragm wear/longer life
- ▶ Cover Pressing, Pressure Plate Casting and Drive Straps manufactured to O.E. standards
- ▶ Non-asbestos friction material made to O.E. specification = resistance to shudder/burst and extended durability/life
- ▶ Forged Splined Hub and heat treated Damper Springs = extended life

Clutch failures will reflect poorly on your business and inconvenience your customer. Be aware of knock off products that have been made to look like EXEDY. Lower quality products are floating around in the market with substandard materials & variations in performance. These products invariably produce excessive wear & tear to the drivetrain of your vehicle or at the very least premature failure of the clutch kit.

Make sure you get the Real Deal and specify EXEDY complete clutch kits.

## Knockoffs are imported and are used in substandard Clutch Kits

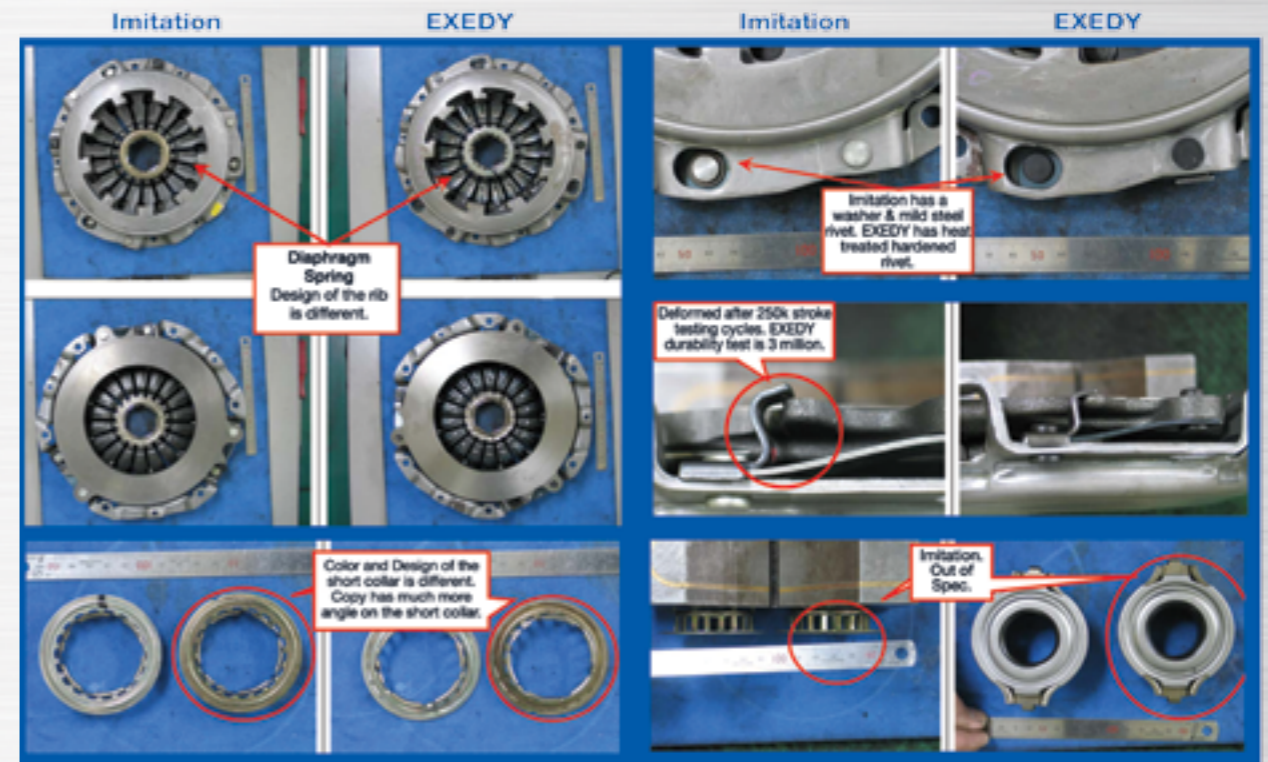

- Clutch Drag = poor disengagement i.e., commonly known as Gearbox Grouch/Gear Crash.
- Malfunction of hydraulic actuation system, due to incorrectly set finger height.
- Vibration or clicking noise in clutch fork, also due to incorrectly set finger height.
- Premature wear of clutch disc, due to PP (pressure plate) tilt lift.
- Damage to clutch disc splines, due to uneven landing of the PP casting on the clutch friction facings.
- All of the above will lead to premature total clutch failure and will snap-out the snap-in bearing.

mm→inch

Facing Outer dia	
mm	inch
150	5 7/8
160	6 1/4
165	6 1/2
170	6 3/4
180	7 1/8
184	7 1/4
190	7 1/2
197	7 3/4
200	7 7/8
203	8
210	8 1/4
212	8 1/4
215	8 1/2
219	8 5/8
220	8 5/8
224	8 7/8
225	8 7/8
228	9
230	9
232	9 1/8
234	9 1/4
235	9 1/4
236	9 1/2
240	9 1/2
242	9 1/2
246	9 5/8
250	9 7/8
254	10
255	10
260	10 1/4
265	10 1/2
270	10 5/8
275	10 7/8
280	11
290	11 1/2
295	11 5/8
300	11 3/4
325	12 3/4
330	13
350	13 3/4
380	15
400	15 3/4
410	16 1/8
430	17
457	18

inch→mm

Facing Outer dia	
inch	mm
5 7/8	150
6 1/4	160
6 1/2	165
6 3/4	170
7	180
7 1/4	184
7 1/2	190
7 3/4	197
7 7/8	200
8	203
8 1/4	210
8 1/4	212
8 1/2	215
8 5/8	219
8 5/8	220
8 7/8	224
8 7/8	225
9	228
9	230
9 1/8	232
9 1/4	234
9 1/4	236
9 1/2	240
9 1/2	242
9 5/8	246
9 7/8	250
10	254
10 1/4	260
10 1/2	265
10 5/8	270
11	280
11 1/2	290
11 5/8	295
11 3/4	300
12	305
12 3/4	325
13	330
14	356
15	380
15 3/4	400
16	406
16 1/8	410
17	430
18	457

mm→inch

Facing Inner dia	
mm	inch
110	4 3/8
120	4 3/4
124	4 7/8
125	4 7/8
127	5
130	5 1/8
132	5 1/8
135	5 3/8
140	5 1/2
145	5 3/4
146	5 3/4
150	5 7/8
154	6 1/8
155.5	6 1/8
160	6 1/4
165	6 1/2
170	6 3/4
175	6 7/8
180	7
190	7 1/2
200	7 7/8
210	8 1/4
220	8 5/8
236	9 1/4
240	9 1/2
240	9 1/2
250	9 7/8
260	10 1/4

mm→inch

SH Major dia	
mm	inch
16.3	5/8
17.4	11/16
18.0	23/32
19.0	3/4
20.0	25/32
20.6	13/16
21.6	27/32
22.2	7/8
23.2	29/32
24.0	15/16
24.3	31/32
25.4	1
26.2	1 1/32
27.0	1 1/16
27.9	1 3/32
28.7	1 1/8
29.4	1 5/32
30.4	1 3/16
32.0	1 1/4
32.4	1 9/32
33.3	1 5/16
35.0	1 3/8
35.3	1 3/8
35.7	1 13/32
36.5	1 7/16
38.1	1 1/2
38.3	1 1/2
38.7	1 17/32
39.7	1 9/16
40.5	1 19/32
41.3	1 5/8
42.0	1 21/32
43.8	1 23/32
44.5	1 3/4
44.8	1 3/4
45.0	1 25/32
48.0	1 29/32
50.0	1 31/32
50.8	2
53.0	2 3/32

# Product Selection Guide



**OEM Replacement:** Made to exacting OE standards as an OE Manufacturer, EXEDY has a comprehensive range of clutch kits for passenger and commercial vehicles.

**Safari Tuff:** Designed and engineered to meet the increased demands of 4WD and commercial use, whilst retaining a comfortable pedal feel.



With over 50 years experience in the performance industry, including victory in the pinnacle of motorsport, Formula 1, EXEDY's advanced clutch solutions are designed and built from the ground up as high performance clutches to suit a variety of driving conditions.

PRODUCT CATEGORY	PRODUCT DESCRIPTION	Image	DRIVING TYPE															
			EVERY DAY DRIVING					PERFORMANCE / MOTORSPORT										
			Everyday Driving	Off-Road	Commercial	Agricultural	Industrial	Street Modified	Track Day	Circuit	Time Attack	Drift	Drag	Rally				
EXEDY	OEM REPLACEMENT		✓	✓	✓	✓	✓											
EXEDY	SAFARI TUFF		✓	✓	✓	✓	✓	✓										
EXEDY RACING CLUTCH	STAGE 1	ORGANIC							✓	✓	✓		✓					
	STAGE 2	SPORTS								✓	✓	✓	✓	✓	✓	✓	✓	
		RACING										✓	✓	✓				
		RALLY											✓	✓			✓	
	RACING FLYWHEEL									✓	✓	✓	✓	✓	✓	✓	✓	
	HYPER SERIES	SINGLE VF									✓	✓						
		SINGLE										✓	✓	✓	✓	✓	✓	
		MULTI	TWIN								✓	✓	✓	✓	✓	✓	✓	
			TRIPLE								✓	✓	✓	✓	✓	✓	✓	
		COMPE-D											✓	✓	✓	✓	✓	
		COMPE-R											✓	✓		✓		
		CARBON-D	SINGLE								✓	✓	✓	✓				
			TWIN								✓	✓	✓	✓				
	CARBON-R		SINGLE										✓	✓	✓			
TWIN											✓	✓	✓					
TRIPLE											✓	✓	✓					

**Important notes:**  
 1) This clutch selection guide is intended as a general guide and you should consult your authorized EXEDY distributor for further clarification of the most suitable EXEDY clutch to suit your requirements.  
 2) Installing a sports / racing clutch can transfer harmonic noises from the engine to gearbox. This is also called gearbox rattle. This is common on most multi-plate clutches and is acceptable within the racing industry.

# EXEDY Clutch Europe Ltd. Aftermarket Warranty and Returns Policy

These are EXEDY Clutch Europe Ltd.'s General Aftermarket Warranty Terms and Conditions and will apply unless specific variations are noted under separate agreements to this document.

## 1. INTRODUCTION

This is the Aftermarket Warranty Statement referred to in the EXEDY Clutch Europe Ltd terms and conditions of sale that covers Warranty and Returns.

## 2. PRODUCTS WARRANTED

This warranty policy applies to all Standard and Sports products, hereinafter referred to as products, sold by EXEDY Clutch Europe Ltd and delivered to the first user on or after date of invoice.

## 3. LIMITED WARRANTY TERMS AND CONDITIONS

EXEDY Clutch Europe Ltd warrants that its products are free from defects in workmanship and material under normal use and services.

The obligation of EXEDY Clutch Europe Ltd for its Standard range products under this warranty is limited to the repair or replacement of products which are deemed to have a manufacturing defect within 12,000miles/19312km or 12 months from date of fitting, whichever occurs first.

The obligation of EXEDY Clutch Europe Ltd for Sports range products under this warranty is limited to the repair or replacement of products which are deemed to have a manufacturing defect within 3,000 miles/4828km or 6 months from date of fitting, whichever comes first.

EXEDY Clutch Europe Limited Warranty will not be valid or offered under the following conditions:

1. Flywheel was not replaced or resurfaced to manufacturers' specifications.
2. EXEDY products have been altered, improperly installed, or damaged by accident, negligence, misapplication or misuse.
3. EXEDY products which are re-boxed in non EXEDY boxes or mixed with or sold in conjunction with 3rd party products.
4. EXEDY standard range products used for high performance and motor sport purposes.
5. Mileages and dates of installation and removal are not included on all claims forms.
6. Incomplete warranty claims forms being submitted to ECE.  
In this case, incomplete claims forms will be returned to the customer. Claims forms must be returned to ECE within a 21 day period for resubmission otherwise the claim will be rejected. ECE will allow two resubmissions per claim; incomplete forms at the second resubmission will be automatically rejected.

## 4. GOODS RETURNS TERMS AND CONDITIONS

1. Customers must initially arrange the return of products to ECE at their own expense.
2. In cases where the claim liability is accepted by ECE, ECE will reimburse the cost of any carriage charges associated with the return to ECE for inspection, providing an official invoice is presented.
3. Accepted claims' products will not be returned to the customer.
4. Accepted claims with labour charges will be paid at £20.00 equivalent per hour.
5. Collection and return of all rejected claims product is the responsibility of the customer; Upon completion of the warranty report, ECE will keep the goods for a period of 30 days after which they will be destroyed.
6. Warranty claims with a labour content must include an official invoice from the repairing garage, clearly showing all costs and any VAT.
7. In cases where claims are accepted, the credit note(s) will be applied to the customer's account within 30 days of acceptance of ECE / EXEDY liability.
8. In instances of mis-packed items or items delivered in an unacceptable condition (by our carrier), ECE warranty and/or shipping department must be informed to arrange for the return of the product(s) to ECE premises.
9. In instances of mis-packed items or items delivered in an unacceptable condition (by our carrier), the product/products should be repacked correctly and sent back to the client at ECE expense or, alternatively, a return of the product/products be fully accepted and a credit note issued as per the customers' requirements.
10. All items returned to ECE must be accompanied with an invoice number upon which they were originally purchased.
11. All warranty returns must include the complete kit and be returned through an authorized EXEDY distributor.



**EXEDY Clutch Europe Ltd.**  
Unit 2, Rokeby Court,  
Runcorn, Cheshire  
United Kingdom  
WA7 1RW

+44 (0) 1928 571850

enquiries@exedy.co.uk

**www.exedy.co.uk**